

# Ball Valves

BF, BFH, BG, BH, BO, BP, BR, BRC,  
BV, BK and BU Series

Ball Valves  
Plug Valves



# Contents

## Trunnion Ball Valves

BF and BFH Series



B-04

## 3-Piece Ball Valves

BG Series



B-11

## 3-Piece Ball Valves

BH Series



B-16

## One-Piece Instrumentation Ball Valves

BO Series



B-24

## Bar Stock Ball Valves

BP Series



B-38

## Hex Bar Stock Ball Valves

BR Series



B-45

## Hex Bar Stock Ball Valves

BRC Series



B-52

## High Performance Ball Valves

BV Series



B-57

## High Temperature Metal-Seated Ball Valves

BK Series

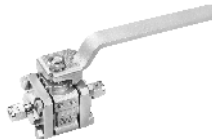

B-67

## Alternative Fuel Service (AFS) Ball Valves

BU Series



B-71

## Important Information about Ball Valves

- ⦿ FITOK ball valves are designed to be used in fully open or fully closed position.
- ⦿ Packing adjustment may be required during the service life of the valve (except for BF, BFH and BU series).
- ⦿ For better quality maintenance, FITOK ball valves should be kept in fully open position in warehouse.
- ⦿ Valves that have not been actuated for a period of time may have a higher initial actuation torque.

# Trunnion Ball Valves

## BF and BFH Series

### Features

- ⦿ Working pressure up to: 10,000 psig (690 bar)
- ⦿ Working temperature: 0°F to 450°F (-18°C to 232°C)
- ⦿ Orifice size: 0.19" (4.8 mm)
- ⦿ Fixed ball with double sealing
- ⦿ Trunnion-style ball to prevent ball blowout
- ⦿ Automatic compensation of seat sealing
- ⦿ Low operating torque
- ⦿ Blowout proof stem
- ⦿ Handle as indicator of flow direction
- ⦿ Positive handle stop
- ⦿ Handle color options available
- ⦿ Pneumatic and electric actuator available
- ⦿ Panel mountable
- ⦿ Leak-tight performance testing with nitrogen or compressed air for every valve at the rated pressure (not higher than 6000 psig) to meet the requirement of no visible leak
- ⦿ Compact maximum-flow design
- ⦿ 2- or 3-way flow patterns
- ⦿ Spring-load seats to provide leak tight integrity in both low-and high-pressure systems and reduce seat wear from pressure surges
- ⦿ The inlet of 3-way valve can be any port
- ⦿ Low-temperature service option available
- ⦿ BF series 3-way ball valves for "fast fill" CNG filling station application available
- ⦿ BF series ball valves with ECE R110 type approval available



### Pressure vs. Temperature

#### BF Series

316 SS Body

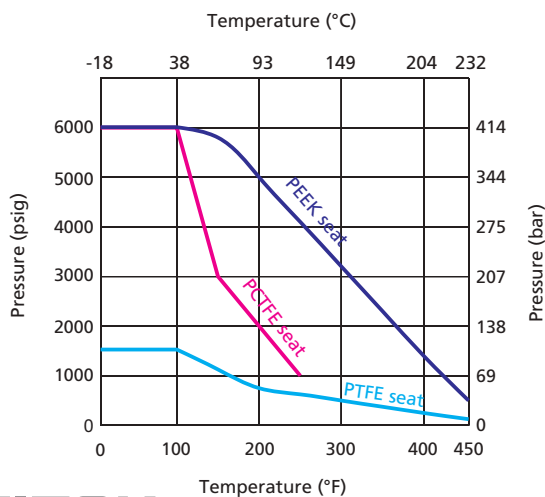

Alloy 400 Body

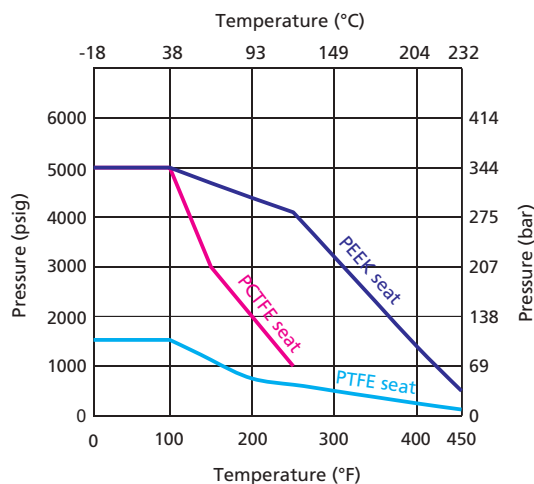

## BFH Series

### 316 SS Body

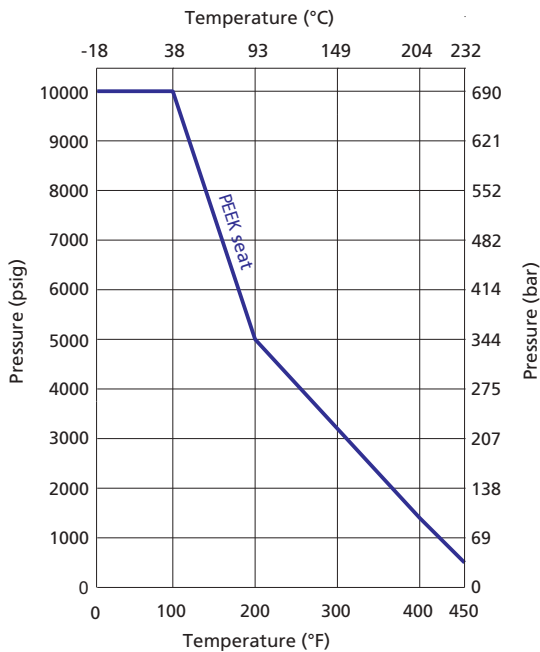

### Pressure Rating@100°F (38°C)

Material	End Connection	Pressure Rating, psig (bar)
316 SS	FNS2, FNS4 FL4, ML6	10000 (690)
	ML10	8400 (578)
	FL6/ML8	7500 (516)
	FL8	6700 (461)
	ML12	6800 (470)

Note: Maximum working pressure of BFH Series ball valves is 10,000 psig. The specified pressure rating is restricted by end connections.

Ball Valves  
Plug Valves

## Standard Materials of Construction

### BF Series

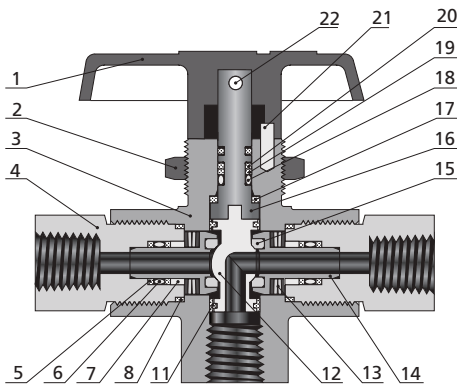
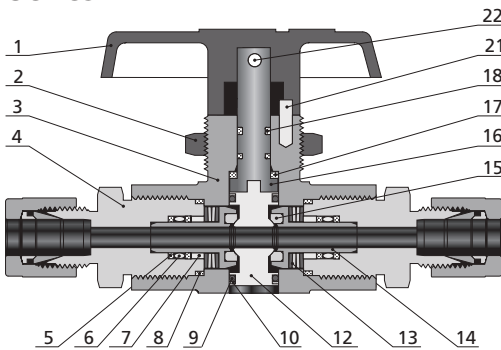

Item	Component	Valve Body Material			
		316 SS		Alloy 400	
		2-way	3-way	2-way	3-way
Material Grade/ASTM Specification					
1	Handle	Nylon with SS insert			
2	Panel Nut	316 SS/A479			
3	Body	<i>F316 SS/A182</i>		<i>Alloy 400/B164</i>	
4	End Connection	<i>316 SS/A479</i>		<i>Alloy 400/B164</i>	
5	Seat Retainer Backup Ring	<i>Reinforced PTFE</i>			
6	Seat Retainer O-ring	<i>Fluorocarbon FKM</i>			
7	Seat Retainer Guide	<i>316 SS/A479</i>		<i>Alloy 400/B164</i>	
8	End Connection Seal	<i>Silver-plated 316L/A269</i>			
9	Trunnion O-ring	<i>Fluorocarbon FKM</i>	—	<i>Fluorocarbon FKM</i>	—
10	Trunnion Backup Ring	<i>Reinforced PTFE</i>	—	<i>Reinforced PTFE</i>	—
11	Trunnion Bearing	—	<i>PEEK</i>	—	<i>PEEK</i>
12	Ball	<i>316 SS/A479</i>	<i>S21800/A479</i>	<i>Alloy 400/B164</i>	
13	Seat Spring	<i>Alloy X-750/AMS 5542</i>			
14	Seat Retainer	<i>316 SS/A479</i>		<i>Alloy 400/B164</i>	
15	Seat	<i>PTFE or PEEK or PCTFE</i>			
16	Stem	<i>316 SS/A479</i>		<i>Alloy 400/B164</i>	
17	Stem Washer	<i>PEEK</i>			
18	Stem O-ring	<i>Fluorocarbon FKM</i>	<i>Fluorocarbon FKM</i>	<i>Fluorocarbon FKM</i>	<i>Fluorocarbon FKM</i>
19	Secondary Stem Backup Ring	—	<i>PTFE/D1710</i>	—	<i>PTFE/D1710</i>
20	Primary Stem Backup Ring	—	<i>PEEK</i>	—	<i>PEEK</i>
21	Stop Pin	<i>SS</i>			
22	Set Screw	<i>Zinc-plated carbon steel</i>			
Lubricants		<i>Fluorinated-based</i>			

Notes: Wetted components are listed in italics.

- Ball trunnions are PTFE coated for BF series 2-way valves.
- For other materials, please contact FITOK Group or our authorized distributors.

**BFH Series**

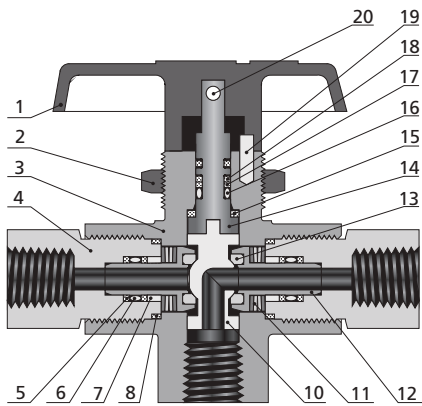
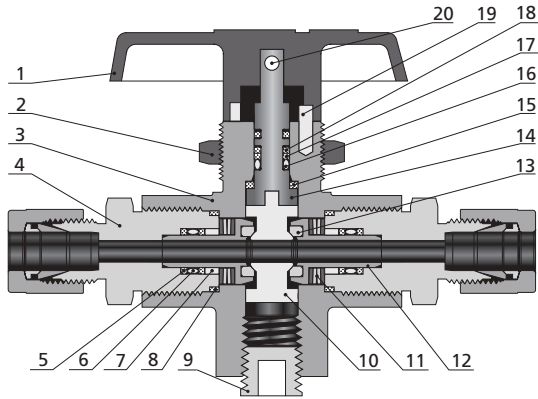

Item	Component	2-way	3-way
		Material Grade/ASTM Specification	
1	Handle	Nylon with SS insert	
2	Panel Nut	316 SS/A479	
3	Body	316 SS/A479	
4	End Connection	316 SS/A479	
5	Seat Retainer Backup Ring	Reinforced PTFE	
6	Seat Retainer O-ring	Fluorocarbon FKM	
7	Seat Retainer Guide	316 SS/A479	
8	End Connection Seal	Silver-plated 316L/A269	
9	Plug	316 SS/A479	
10	Ball	S21800/A479	
11	Seat Spring	Alloy X-750/AMS 5542	
12	Seat Retainer	316 SS/A479	
13	Seat	PEEK	
14	Stem	316 SS/A479	
15	Stem Washer	PEEK	
16	Stem O-ring	Fluorocarbon FKM	
17	Secondary Stem Backup Ring	PTFE/D1710	
18	Primary Stem Backup Ring	PEEK	
19	Stop Pin	SS	
20	Set Screw	Zinc-plated carbon steel	
<i>Lubricants</i>		<i>Fluorinated-based</i>	

Notes: Wetted components are listed in italics.

1. Ball trunnions are PTFE coated for BFH series ball valves.

2. For other materials, please contact FITOK Group or our authorized distributors.

**Dimensions**

**2-way Valves**

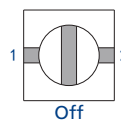
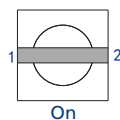
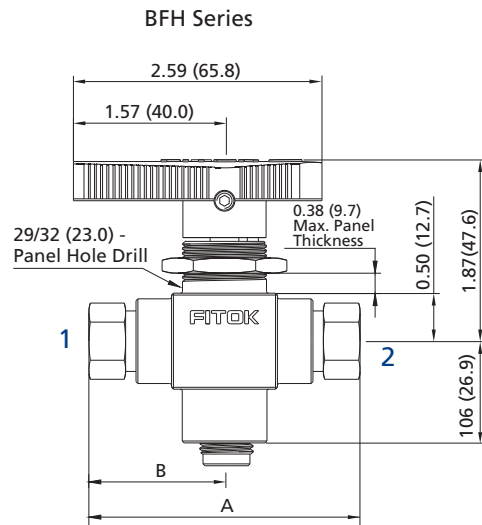
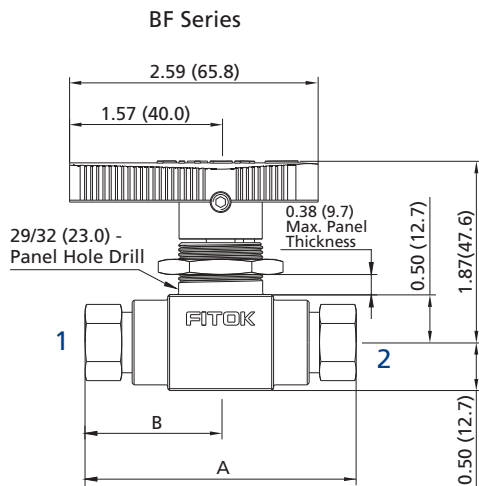

Basic Ordering Number		Connection Type and Size		Orifice in. (mm)	Cv	Dimensions, in. (mm)	
BF Series	BFH Series	Connection 1/2				A	B
BF□□-FNS2	BFH□□-FNS2-P	1/8 Female NPT		0.19 (4.8)	1.2	2.94 (74.7)	1.47 (37.3)
BF□□-FNS4	BFH□□-FNS4-P	1/4 Female NPT					
BF□□-FNS8	BFH□□-FNS4-P	1/2 Female NPT			1.0	3.93 (99.8)	1.97 (50.0)
BF□□-FL4	BFH□□-FL4-P	1/4" FITOK			1.2	4.25 (108.0)	2.13 (54.1)
BF□□-FL6	BFH□□-FL6-P	3/8" FITOK			1.6	4.14 (105.2)	2.07 (52.6)
BF□□-FL8	BFH□□-FL8-P	1/2" FITOK			1.4	4.39 (111.5)	2.19 (55.6)
BF□□-ML6	BFH□□-ML6-P	6 mm FITOK			1.0	4.60 (116.8)	2.30 (58.4)
BF□□-ML8	BFH□□-ML8-P	8 mm FITOK			1.6	4.14 (105.2)	2.07 (52.6)
BF□□-ML10	BFH□□-ML10-P	10 mm FITOK			1.5	4.15 (105.4)	2.07 (52.6)
BF□□-ML12	BFH□□-ML12-P	12 mm FITOK			1.3	4.41 (112.0)	2.20 (55.9)
					1.0	4.60 (116.8)	2.30 (58.4)

### 3-way Valves

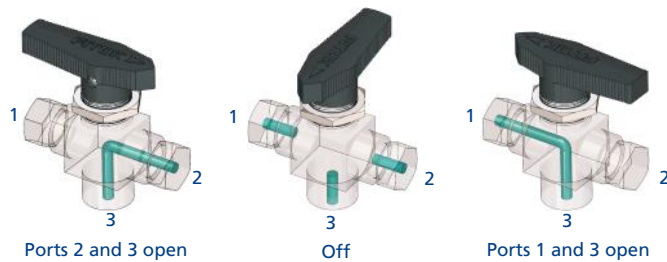
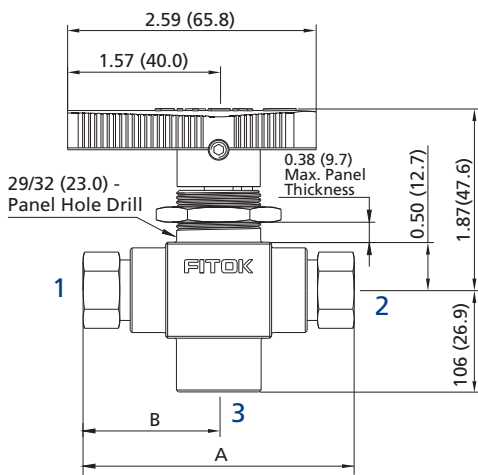

Basic Ordering Number		Connection Type and Size		Orifice in. (mm)	Cv	Dimensions, in. (mm)	
BF Series	BFH Series	Connection 1/2	Connection 3			A	B
BF□□-FNS2-3	BFH□□-FNS2-P-3	1/8 Female NPT	1/4 Female NPT	0.19 (4.8)	0.75	2.94 (74.7)	1.47 (37.3)
BF□□-FNS4-3	BFH□□-FNS4-P-3	1/4 Female NPT					
BF□□-FL4-3	BFH□□-FL4-P-3	1/4" FITOK				3.93 (99.8)	1.97 (50.0)
BF□□-FL6-3	BFH□□-FL6-P-3	3/8" FITOK				4.14 (105.2)	2.07 (52.6)
BF□□-FL8-3	BFH□□-FL8-P-3	1/2" FITOK				4.39 (111.5)	2.19 (55.6)
BF□□-ML6-3	BFH□□-ML6-P-3	6 mm FITOK				4.60 (116.8)	2.30 (58.4)
BF□□-ML8-3	BFH□□-ML8-P-3	8 mm FITOK				4.14 (105.2)	2.07 (52.6)
BF□□-ML10-3	BFH□□-ML10-P-3	10 mm FITOK				4.15 (105.4)	2.07 (52.6)
BF□□-ML12-3	BFH□□-ML12-P-3	12 mm FITOK				4.41 (112.0)	2.20 (55.9)
						4.60 (116.8)	2.30 (58.4)

1. FITOK means FITOK double ferrule tube fittings.
2. Sizes and types listed are standard. Other sizes and types are available upon request, please contact FITOK Group or our authorized distributors.
3. Dimensions are shown with tube fitting nuts finger-tightened. All dimensions are for reference only and are subject to change.  
For dimensions not shown above, please contact FITOK Group or our authorized distributors.
4. Bottom port of all 3-way valves is 1/4 in. female NPT.

## Special Application Ball Valves

### Low-Temperature Service

BF and BFH series ball valves for low-temperature service, with a temperature rating of -40°F to 200°F (-40°C to 93°C), are available.

Low-temperature service valves have low-temperature NBR O-rings. All other materials are the same as those of standard valves. To order a valve for low-temperature service, add -LT into the valve ordering number.

For example: BFSS-FL4-P-LT

BFSS-FL4-P-3-LT

Seal kit for field replacement is available, see "Seal Kits" on Page B-09.

### Low-Temperature Service BF Series Pressure vs. Temperature

316 SS Body

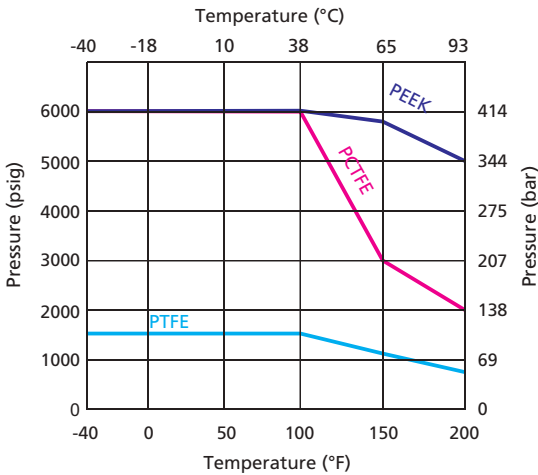

Alloy 400 Body

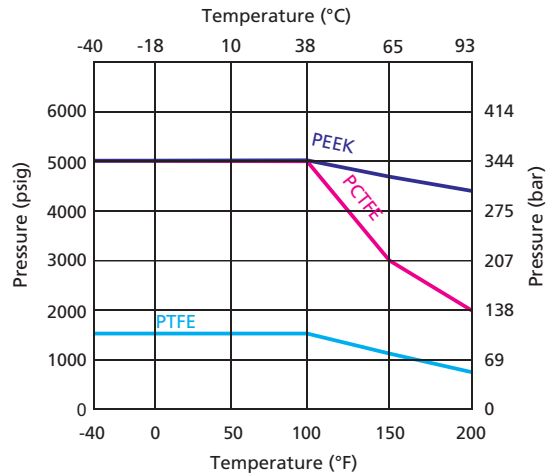

### Low-Temperature Service BFH Series Pressure vs. Temperature

316 SS Body

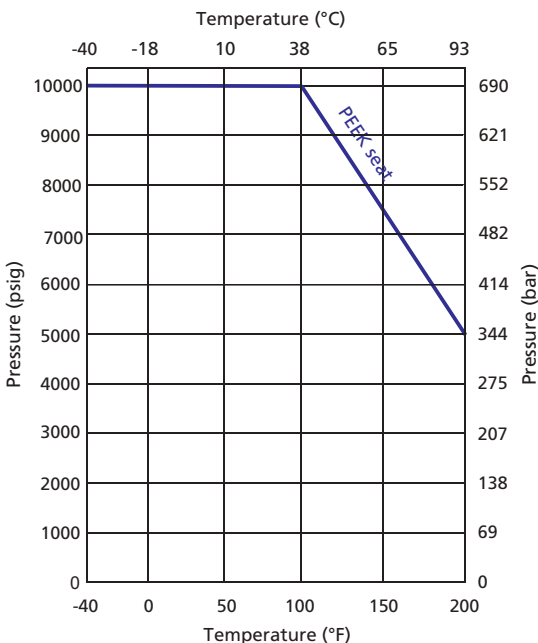

Note: The maximum working pressure for BFH series low-temperature service ball valves is the same as that of standard ball valves.

### "Fast Fill" CNG Filling Station Application

BF series 3-way valves for use in "fast-fill" CNG filling station as well as a variety of filling station applications are available.

#### Features

- A directional installation with 90 degree actuation for ease of operation during filling
  - 3-way design with vent port for ease of venting after fill
  - PEEK seats to reduce maintenance required in high-cycle applications
  - Cycle life test report available upon request
  - Field repairable with seal kit, see "Seal Kits" on Page B-09
- To order, the flow pattern designator should be specified as "3DL" in the valve ordering number.

Example: BFSS-FNS4-P-3DL (The material and pressure vs. temperature curve are the same with those of BF series standard valves.)  
 BFSS-FNS4-P-3DL-LT (The material and pressure vs. temperature curve are the same with those of BF series low-temperature service valves.)

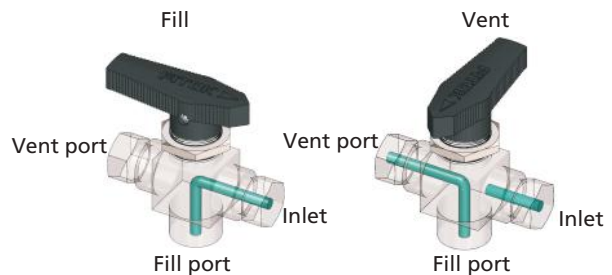

## CNG/NGV Application

BF series ball valves with ECE R110 manual valve type approval available.

Classification: Class 0

Temperature rating: -40°F to 248°F (-40°C to 120°C)

Pressure rating: 3770 psig (260 bar)

CNG/NGV application valves have low-temperature FKM O-rings and PEEK seats. All other materials are the same as those of standard valves.

To order a valve for CNG/NGV application, add **-R110** into the valve ordering number.

For example: BFSS-FL4-P-**R110**

BFSS-FL4-P-3-**R110**

Seal kit for field replacement is available, see "Seal Kits" on Page B-09.

## Seal Kits

Valve Series	Flow Pattern	Special Application	Basic Seal Kit Ordering Number	Content
BF	2-way	/	BFSS-2-□	Seat retainer backup ring, seat retainer O-ring, seat retainer guide, end connection seal, trunnion O-ring, trunnion backup ring, ball, seat spring, seat retainer, seat, stem, stem washer, stem O-ring, instructions.
		Low-temperature service	BFSS-2-□-LT	
		CNG/NGV application	BFSS-2-P-R110	
	3-way	/	BFSS-3-□	Seat retainer backup ring, seat retainer O-ring, seat retainer guide, end connection seal, trunnion bearing, ball, seat spring, seat retainer, seat, stem, stem washer, stem O-ring, secondary stem backup ring, primary stem backup ring, instructions.
		Low-temperature service	BFSS-3-□-LT	
		"Fast Fill" CNG filling station application	BFSS-3DL-P	
CNG/NGV application		BFSS-3DL-P-LT		
BFH	2-way	/	BFHSS-2-P	Seat retainer backup ring, seat retainer O-ring, seat retainer guide, end connection seal, ball, seat spring, seat retainer, seat, stem, stem washer, stem O-ring, secondary stem backup ring, primary stem backup ring, instructions.
		Low-temperature service	BFHSS-2-P-LT	
	3-way	/	BFHSS-3-P	
		Low-temperature service	BFHSS-3-P-LT	

Seat Material	Designator
PTFE	T
PCTFE	K
PEEK	P

1. Seal kit components are the same materials and grades listed in materials of construction.

2. To order seal kits for BF series standard and low-temperature service ball valves, select a seat designator from the table at left and add to the basic seal kit ordering number.

Example: BFSS-2-T

BFSS-2-P-LT

3. The listed basic seal kit ordering numbers specify 316 stainless steel material.

To order kits with other materials, such as Alloy 400 material, replace "SS" with "M" in the ordering number.

Example: BFM-2-T

## Locking Device

⊙ Lock BF series 2-way or 3-way valves, locking hole diameter is 0.21 in (5.2 mm).

⊙ To order a ball valve with locking device, add **-L** to the valve ordering number.

Example: BFSS-ML6-L/BFSS-ML6-3-L

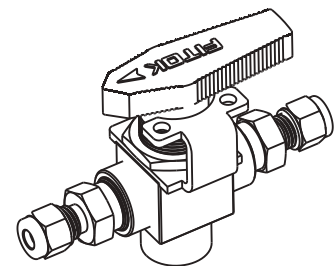

## Ball Valve without Handle

⊙ Ball Valve without handle can be directly connected to the FITOK actuator assembly.

⊙ To order, please add **-AM** to the valve ordering number.

Example: BFSS-FL4-P-AM



# 3-Piece Ball Valves

## BG Series

### Features

- ⦿ Working pressure up to: 1000 psig (69.0 bar)
- ⦿ Working temperature: -20°F to 450°F (-28°C to 232°C)
- ⦿ End connections:
  - 1/8 to 1 thread
  - 1/8" to 1" pipe butt or socket weld
  - 1/4" to 1" and 6 mm to 25 mm tube butt or socket weld
  - 1/4" to 1" and 6 mm to 25 mm tube fitting
- ⦿ Orifice sizes: 0.19" (4.8 mm) to 1" (25 mm)
- ⦿ Blowout proof stem
- ⦿ Bidirectional flow
- ⦿ Leak-tight performance testing with nitrogen or compressed air for every valve at the rated pressure to meet the requirement of no visible leak



### Pressure vs. Temperature

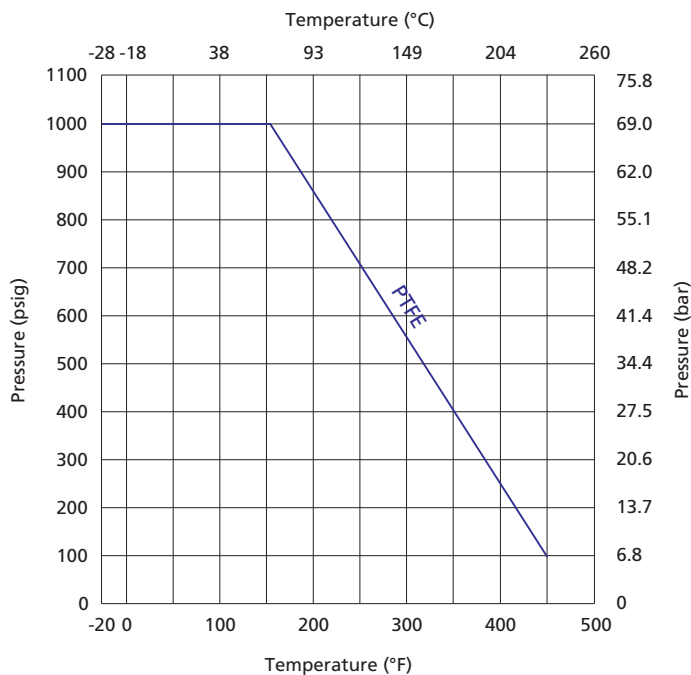

Note: The temperature and pressure rating are based on valves of standard materials.

## Standard Materials of Construction

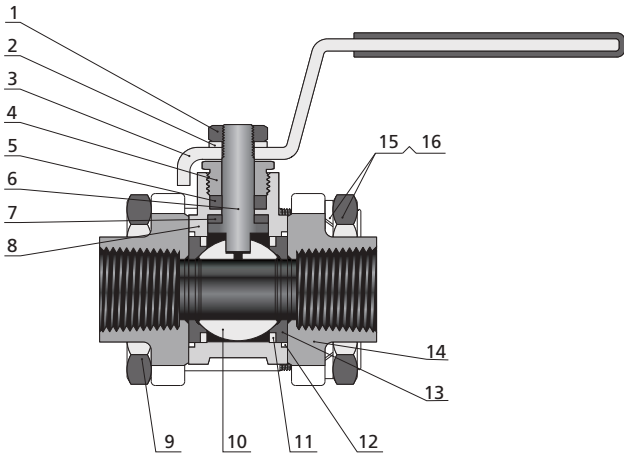

Item	Component	Valve Body Material	
		CF8M/A351	CF8/A351
1	Stem Nut	SS	
2	Gasket	SS	
3	Handle	304 SS/A240 (with vinyl sleeve)	
4	Gland	316 SS/A479 or 304 SS/A479	
5	Stem Packing	PTFE/D1710	
6	Stem	316 SS/A479 or 304 SS/A479	
7	Stem Bearing	PTFE/D1710	
8	Body	CF8M/A351	CF8/A351
9	Body Bolt	SS	
10	Ball	316 SS/A479 or 304 SS/A479	
11	Support Ring	316 SS/A240 or 304 SS/A240	
12	Flange Seal	PTFE/D1710	
13	Seat	PTFE/D1710	
14	End Connection	CF8M/A351	CF8/A351
15	Gasket	SS	
16	Nut	SS	
Lubricants		Silicone-based and PTFE-based	

Note: Wetted components are listed in italics.

For other materials, please contact FITOK Group or our authorized distributors.

## Dimensions

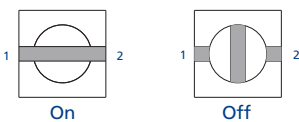
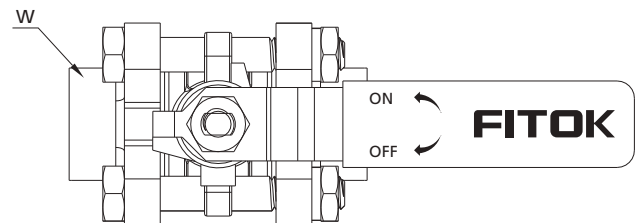
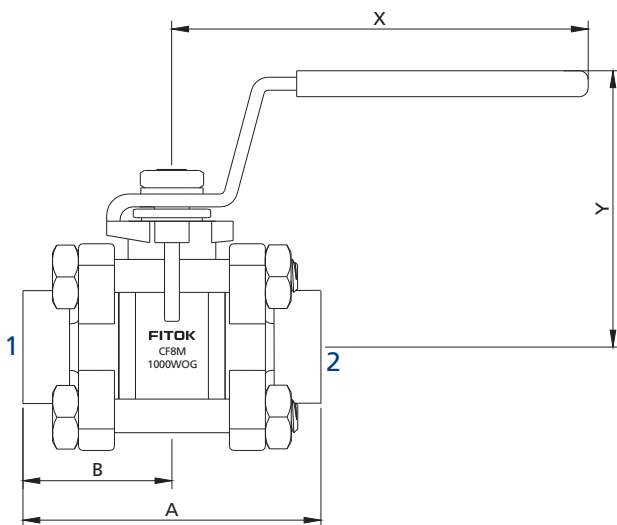

Basic Ordering Number	Connection Type and Size		Orifice in. (mm)	Cv	Dimensions, in. (mm)				
	Connection 1	Connection 2			A	B	W	X	Y
BG□□-FNS2-05	1/8 Female NPT	1/8 Female NPT	0.19 (4.8)	1.2	2.05 (52.1)	1.03 (26.0)	0.63 (16.0)	2.69 (68.3)	1.46 (37.0)
BG□□-FRP2-05	1/8 Female BSPP	1/8 Female BSPP							
BG□□-PB4-05	1/4×SCH80 Pipe Butt Weld	1/4×SCH80 Pipe Butt Weld							
BG□□-FL4-05	1/4" FITOK	1/4" FITOK							
BG□□-ML6-05	6 mm FITOK	6 mm FITOK							
BG□□-ML8-05	8 mm FITOK	8 mm FITOK							
BG□□-FNS4-07	1/4 Female NPT	1/4 Female NPT	0.28 (7.1)	3.8	2.05 (52.1)	1.03 (26.0)	0.93 (23.5)	3.94 (100.0)	2.19 (55.7)
BG□□-FRP4-07	1/4 Female BSPP	1/4 Female BSPP							
BG□□-FL6-07	3/8" FITOK	3/8" FITOK							
BG□□-ML10-07	10 mm FITOK	10 mm FITOK							
BG□□-FL8-11	1/2" FITOK	1/2" FITOK	0.42 (10.6)	7.5	4.04 (103.0)	2.02 (51.3)			
BG□□-ML12-11	12 mm FITOK	12 mm FITOK							
BG□□-ML14-11	14 mm FITOK	14 mm FITOK							
BG□□-FNS6-13	3/8 Female NPT	3/8 Female NPT	0.50 (12.7)	11.3	2.57 (65.2)	1.28 (32.6)	0.93 (23.5)	3.94 (100.0)	2.19 (55.7)
BG□□-FRP6-13	3/8 Female BSPP	3/8 Female BSPP							
BG□□-PS6-13	3/8 PS	3/8 PS							
BG□□-PB8-13	1/2×SCH80 Pipe Butt Weld	1/2×SCH80 Pipe Butt Weld							
BG□□-FL10-13	5/8" FITOK	5/8" FITOK							
BG□□-ML16-13	16 mm FITOK	16 mm FITOK							
BG□□-FNS8-15	1/2 Female NPT	1/2 Female NPT	0.55 (14.0)	13.0	2.74 (69.5)	1.37 (34.8)	1.06 (27.0)	3.94 (100.0)	2.26 (57.5)
BG□□-FRP8-15	1/2 Female BSPP	1/2 Female BSPP							
BG□□-PS8-15	1/2 PS	1/2 PS							
BG□□-MTB22-15	22×3 mm Tube Butt Weld	22×3 mm Tube Butt Weld							
BG□□-TS12-15	3/4" TS	3/4" TS							
BG□□-MTS18-15	18 mm Tube Socket Weld	18 mm Tube Socket Weld							
BG□□-FL12-15	3/4" FITOK	3/4" FITOK							
BG□□-ML18-15	18 mm FITOK	18 mm FITOK							
BG□□-FNS12-20	3/4 Female NPT	3/4 Female NPT	0.79 (20.0)	50.0	3.15 (80.0)	1.57 (40.0)	1.34 (34.0)	5.18 (131.5)	2.66 (67.5)
BG□□-FRP12-20	3/4 Female BSPP	3/4 Female BSPP							

## B-14 Ball Valves

Basic Ordering Number	Connection Type and Size		Orifice in. (mm)	Cv	Dimensions, in. (mm)				
	Connection 1	Connection 2			A	B	W	X	Y
BG□□-PB12-20	3/4×SCH80 Pipe Butt Weld	3/4×SCH80 Pipe Butt Weld	0.79 (20.0)	50.0	3.15 (80.0)	1.57 (40.0)	1.34 (34.0)	5.18 (131.5)	2.66 (67.5)
BG□□-PS12-20	3/4 PS	3/4 PS							
BG□□-TS16-20	1" TS	1" TS							
BG□□-MTB25-20	25×3.5 mm Tube Butt Weld	25×3.5 mm Tube Butt Weld							
BG□□-MTS25-20	25 mm Tube Socket Weld	25 mm Tube Socket Weld			5.12 (130.0)	2.56 (65.0)	1.57 (40.0)	5.95 (151.2)	3.08 (78.2)
BG□□-FL16-20	1" FITOK	1" FITOK							
BG□□-ML22-20	22 mm FITOK	22 mm FITOK							
BG□□-ML25-20	25 mm FITOK	25 mm FITOK							
BG□□-FNS16-25	1 Female NPT	1 Female NPT	0.98 (25.0)	93.0	3.54 (90.0)	1.77 (45.0)	1.57 (40.0)	5.95 (151.2)	3.08 (78.2)
BG□□-FRP16-25	1 Female BSPP	1 Female BSPP							
BG□□-PS16-25	1 PS	1 PS							
BG□□-PB16-25	1×SCH80 Pipe Butt Weld	1×SCH80 Pipe Butt Weld							

1. FITOK means FITOK double ferrule tube fittings, TS means fractional tube socket weld, MTS means metric tube socket weld, TB means fractional tube butt weld, MTB means metric tube butt weld, PS means pipe socket weld, and PB means pipe butt weld.
2. Butt welding ends are manually welded. For connections with orbital welding, please contact FITOK Group or our authorized distributors.
3. Sizes and types listed are standard. Other sizes and types are available upon request, please contact FITOK Group or our authorized distributors.
4. Dimensions are shown with tube fitting nuts finger-tightened. All dimensions are for reference only and are subject to change. For dimensions not shown above, please contact FITOK Group or our authorized distributors.

## Seal Kits

Valve Orifice	Basic Seal Kit Ordering Number	Content
05/07	T-BG-2-RK	Seat, flange seal, lower packing, upper packing, instructions
11/13	T-BG-4-RK	
15	T-BG-6-RK	
20	T-BG-12-RK	
25	T-BG-16-RK	Seat, flange seal, stem bearing, packing support, lower packing, upper packing, instructions

## Locking Device

- ⊙ Lock BG series valves, locking hole diameters of:
  - valves with orifice 05 or 07 are 0.185 in (4.7 mm);
  - valves with orifice 11, 13, 15, or 20 are 0.22 in (5.7 mm);
  - valves with orifice 25 are 0.19 in (4.8 mm)
- ⊙ To order a ball valve with locking device, add -L to the valve ordering number.  
Example: BGSS-FRT8-15-L

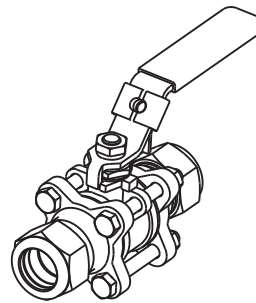

Diagram of Ball Valves with Locking Device and Orifice 05, 07, 11, 13, 15, or 20

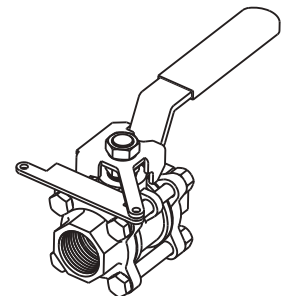
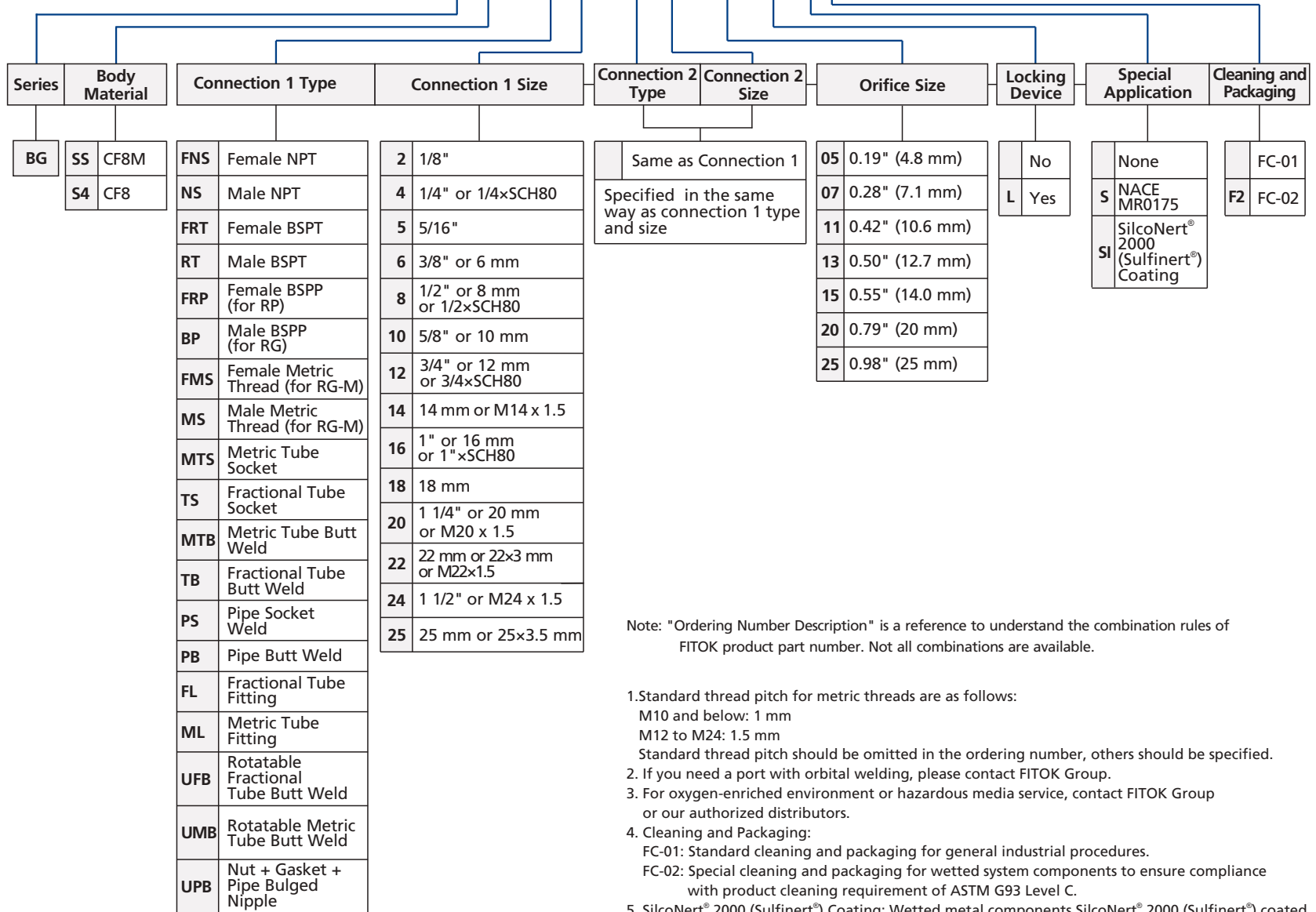

Diagram of Ball Valves with Locking Device and Orifice 25

# Ordering Number Description

BGSS - FNS8 - ML18 - 15 - L - SF2



Note: "Ordering Number Description" is a reference to understand the combination rules of FITOK product part number. Not all combinations are available.

- Standard thread pitch for metric threads are as follows:  
M10 and below: 1 mm  
M12 to M24: 1.5 mm  
Standard thread pitch should be omitted in the ordering number, others should be specified.
- If you need a port with orbital welding, please contact FITOK Group.
- For oxygen-enriched environment or hazardous media service, contact FITOK Group or our authorized distributors.
- Cleaning and Packaging:  
FC-01: Standard cleaning and packaging for general industrial procedures.  
FC-02: Special cleaning and packaging for wetted system components to ensure compliance with product cleaning requirement of ASTM G93 Level C.
- SilcoNert® 2000 (Sulfinert®) Coating: Wetted metal components SilcoNert® 2000 (Sulfinert®) coated.

# 3-Piece Ball Valves

## BH Series

### Features

- ⦿ Working pressure up to: 3000 psig (207 bar)
- ⦿ Working temperature: -20°F to 450°F (-28°C to 232°C)
- ⦿ End connections:
  - 1/8 to 2 thread
  - 1/8" to 2" pipe butt or socket weld
  - 1/4" to 2" and 6 mm to 50 mm tube butt or socket weld
  - 1/4" to 2" and 6 mm to 38 mm tube fitting
- ⦿ 3-piece precision cast body construction
- ⦿ Orifice sizes: 0.19" (4.8 mm) to 1.5" (38.1 mm)
- ⦿ Blowout proof stem
- ⦿ Pneumatic and electric actuator available
- ⦿ Bidirectional flow for 2-way valves
- ⦿ Bottom port as inlet for 3-way valves
- ⦿ Leak-tight performance testing with nitrogen or compressed air for every valve at the rated pressure to meet the requirement of no visible leak

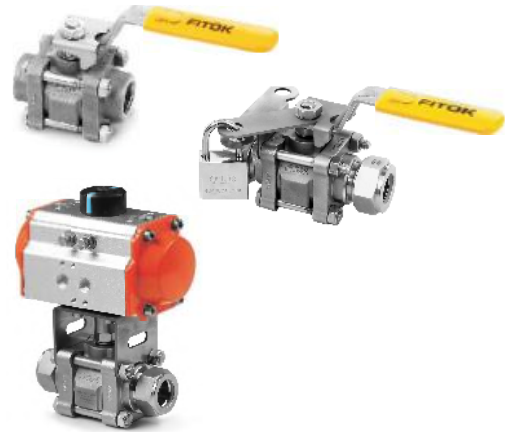

### Pressure vs. Temperature

#### 2-way Valves

Orifice Size: 0.19", 0.28", 0.41", 0.52" & 0.88"

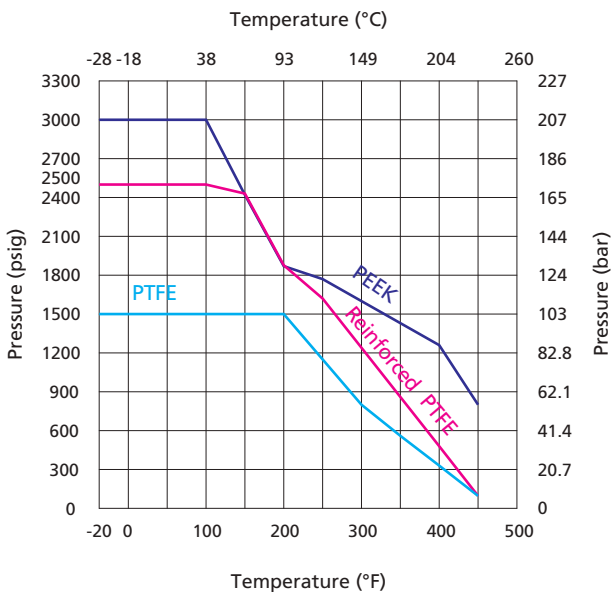

Orifice Size: 1.13", 1.25" & 1.50"

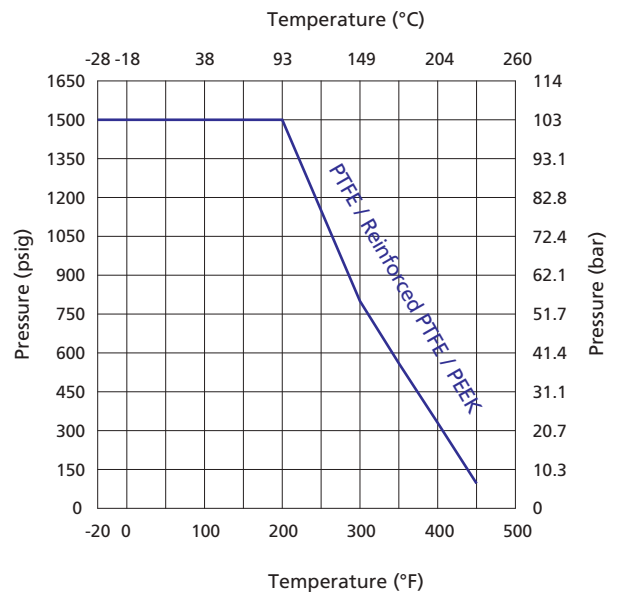

### 3-way Valves

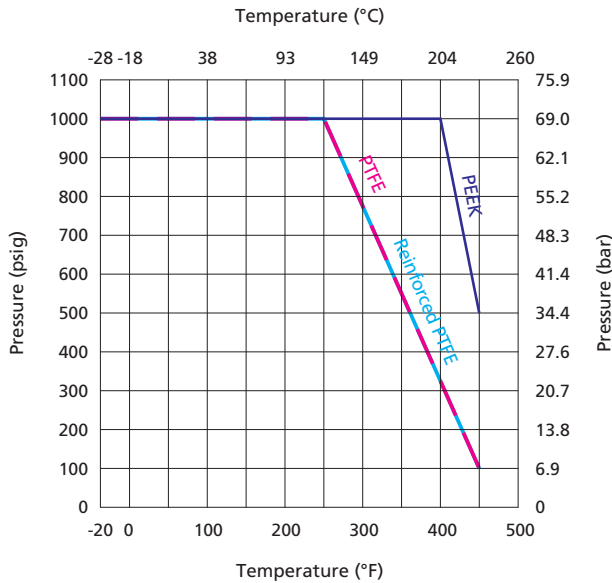

Note: The temperature and pressure rating are based on valves of standard materials.

### Standard Materials of Construction

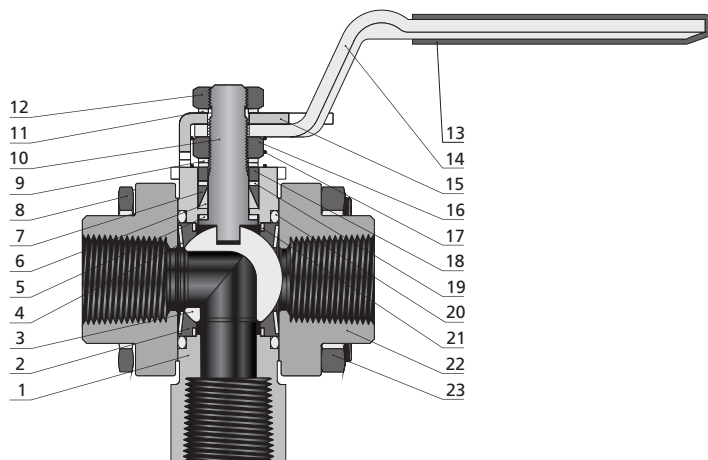
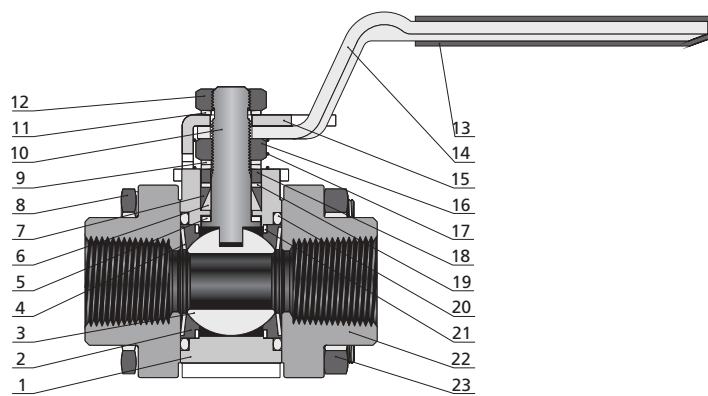

Item	Component	Material Grade/ASME Specification	
1	<i>Body</i>	<i>CF8M/A351</i>	<i>CF8/A351</i>
2	<i>Seat</i>	<i>PTFE or Reinforced PTFE or PEEK</i>	
3	<i>Ball</i>	<i>316 SS/A479</i>	
4	<i>Coned-disc Spring</i>	<i>Strain-hardened 316 SS/A240</i>	
5	<i>Stem Bearing</i>	<i>PEEK</i>	
6	<i>Lower Packing</i>	<i>Reinforced PTFE</i>	
7	<i>Upper Packing</i>	<i>Reinforced PTFE</i>	
8	Body Bolt	Gr. B8M/A193	
9	Stem Spring	Strain-hardened 316 SS/A240	
10	<i>Stem</i>	<i>316 SS/A479</i>	
11	Stem Spring	Strain-hardened 316 SS/A240	
12	Stem Nut	Gr. 8M/A194	
13	Handle Sleeve	Vinyl	
14	Handle	304 SS/A240	
15	Stop Plate	304 SS/A240	
16	Stem Nut	Gr. 8M/A194	
17	Grounding Spring	302 SS/A313	
18	Gland	PTFE-coated 316 SS/A479	
19	<i>Packing Support</i>	<i>PEEK</i>	
20	<i>Flange Seal</i>	<i>PTFE/D1710</i>	
21	<i>Support Ring</i>	<i>316 SS/A240</i>	
22	<i>End Connection</i>	<i>CF8M/A351</i>	<i>CF8/A351</i>
23	Body Nut	Gr.8M/A194	
<i>Lubricants</i>		<i>Silicone-based and PTTE-based</i>	

Note: Wetted components are listed in italics.  
For other materials, please contact FITOK Group or our authorized distributors.

## Dimensions

### 2-way Valves

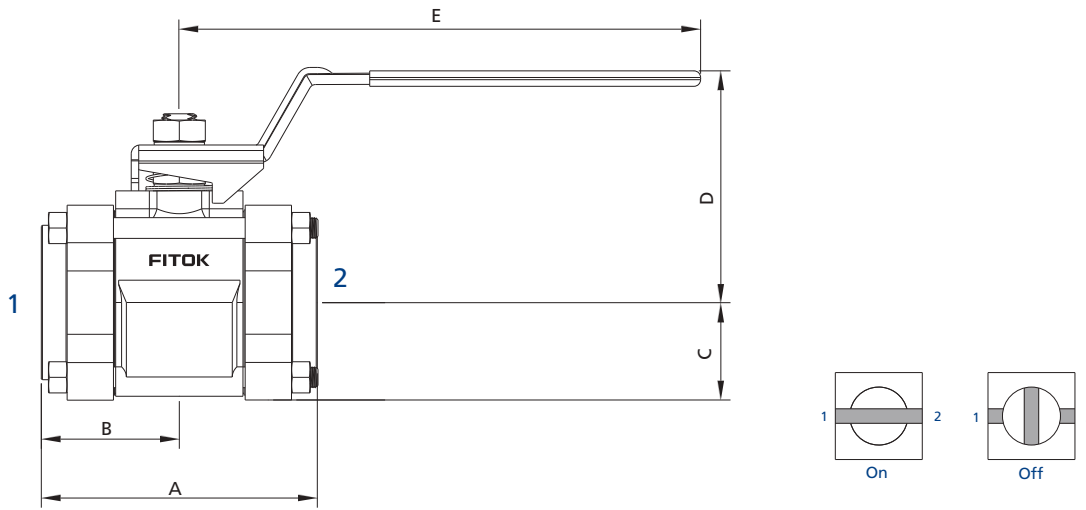

### 3-way Valves

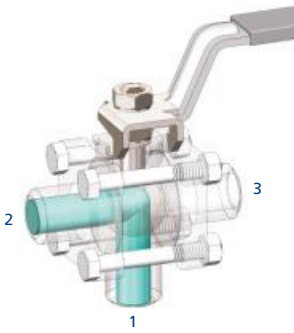
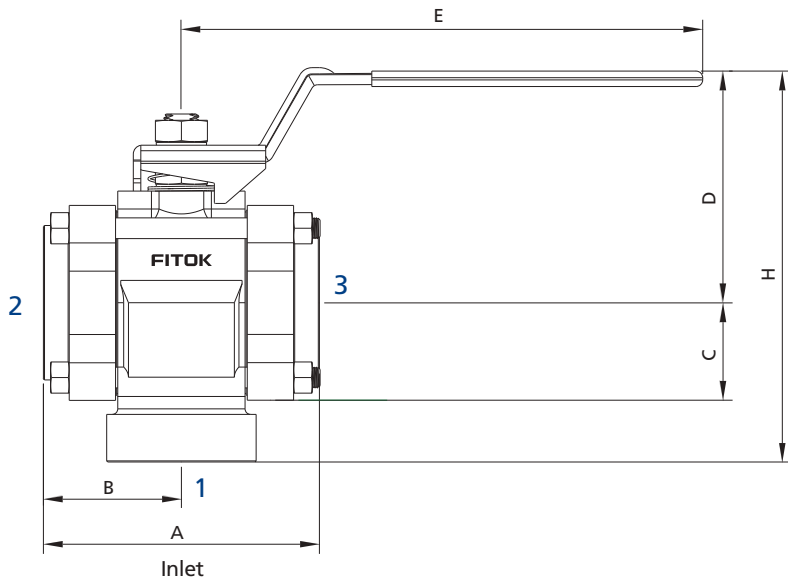

Port 1 to port 2

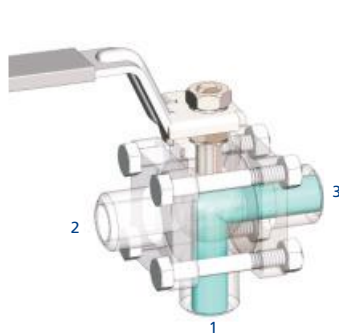

Port 1 to port 3

Basic Ordering Number		Connection Type and Size		Orifice in. (mm)		Cv		Dimensions, in. (mm)														
2-way	3-way	Connection 1	Connection 2/3	2-way	3-way	2-way	3-way	A	B	C	D	E	H									
BH□□-FL4-05	BH□□-FL4-05-3	1/4" FITOK	1/4" FITOK	0.19 (4.8)	0.19 (4.8)	1.2	1.2	3.17 (80.5)	1.59 (40.4)	0.68 (17.3)	1.66 (42.2)	2.37 (60.2)	3.35 (85.1)									
BH□□-ML6-05	BH□□-ML6-05-3	6 mm FITOK	6 mm FITOK																			
BH□□-ML8-05	BH□□-ML8-05-3	8 mm FITOK	8 mm FITOK																			
BH□□-TS4-05	—	1/4" TS	1/4" TS		—	1.2	—	2.16 (54.9)	1.08 (27.4)	—	—	—										
BH□□-MTS6-05	—	6 mm Tube Socket Weld	6 mm Tube Socket Weld																			
BH□□-PB4-05	—	1/4×SCH80 Pipe Butt Weld	1/4×SCH80 Pipe Butt Weld																			
BH□□-FNS2-07	BH□□-FNS2-07-3	1/8 Female NPT	1/8 Female NPT	0.28 (7.1)	0.28 (7.1)	3.8	1.7	2.16 (54.9)	1.08 (27.4)	0.68 (17.3)	1.66 (42.2)	2.37 (60.2)	3.12 (79.2)									
BH□□-FRT2-07	BH□□-FRT2-07-3	1/8 Female BSPT	1/8 Female BSPT																			
BH□□-FRP2-07	BH□□-FRP2-07-3	1/8 Female BSPP	1/8 Female BSPP																			
BH□□-FNS4-07	BH□□-FNS4-07-3	1/4 Female NPT	1/4 Female NPT																			
BH□□-FRT4-07	BH□□-FRT4-07-3	1/4 Female BSPT	1/4 Female BSPT																			
BH□□-FRP4-07	BH□□-FRP4-07-3	1/4 Female BSPP	1/4 Female BSPP																			
BH□□-FL6-07	BH□□-FL6-07-3	3/8" FITOK	3/8" FITOK											3.17 (80.5)	1.59 (40.4)	—	—	—	—	—	—	4.37 (111)
BH□□-ML10-07	BH□□-ML10-07-3	10 mm FITOK	10 mm FITOK																			
BH□□-TS6-07	—	3/8" TS	3/8" TS											—	—	—	2.16 (54.9)	1.08 (27.4)	—	—	—	—
BH□□-PB6-07	—	3/8×SCH80 Pipe Butt Weld	3/8×SCH80 Pipe Butt Weld																			
BH□□-FL8-10	BH□□-FL8-10-3	1/2" FITOK	1/2" FITOK	0.41 (10.4)	0.41 (10.4)	7.5	3.5	4.04 (103)	2.02 (51.3)	0.89 (22.6)	2.35 (59.7)	4.50 (114)	4.48 (114)									
BH□□-ML12-10	BH□□-ML12-10-3	12 mm FITOK	12 mm FITOK																			
BH□□-TS8-10	—	1/2" TS	1/2" TS																			
BH□□-FNS6-13	BH□□-FNS6-13-3	3/8 Female NPT	3/8 Female NPT	0.52 (13.1)	0.52 (13.1)	12.0	5.0	2.70 (68.6)	1.35 (34.3)	—	—	—	4.19 (106)									
BH□□-FRT6-13	BH□□-FRT6-13-3	3/8 Female BSPT	3/8 Female BSPT																			
BH□□-FRP6-13	BH□□-FRP6-13-3	3/8 Female BSPP	3/8 Female BSPP																			
BH□□-FNS8-13	BH□□-FNS8-13-3	1/2 Female NPT	1/2 Female NPT																			
BH□□-FRT8-13	BH□□-FRT8-13-3	1/2 Female BSPT	1/2 Female BSPT																			
BH□□-FRP8-13	BH□□-FRP8-13-3	1/2 Female BSPP	1/2 Female BSPP																			
BH□□-FL12-13	BH□□-FL12-13-3	3/4" FITOK	3/4" FITOK											4.04 (103)	2.02 (51.3)	—	—	—	—	—	—	—
BH□□-ML16-13	BH□□-ML16-13-3	16 mm FITOK	16 mm FITOK																			
BH□□-ML18-13	BH□□-ML18-13-3	18 mm FITOK	18 mm FITOK											—	—	13.6	—	2.70 (68.6)	1.34 (34)	—	—	—
BH□□-TS12-13	—	3/4" TS	3/4" TS																			
BH□□-PS8-13	—	1/2 PS	1/2 PS																			
BH□□-PB8-13	—	1/2×SCH80 Pipe Butt Weld	1/2×SCH80 Pipe Butt Weld	—	—	6.8	—	2.69 (68.3)	1.34 (34)	—	—	—										
BH□□-PB12-13	—	3/4×SCH80 Pipe Butt Weld	3/4×SCH80 Pipe Butt Weld																			
BH□□-FNS12-22	BH□□-FNS12-22-3	3/4 Female NPT	3/4 Female NPT	0.88 (22.2)	0.71 (18.0)	31.0	12.0	3.59 (91.2)	1.8 (45.7)	1.25 (31.8)	2.94 (74.7)	6.00 (152)	5.45 (138)									
BH□□-FRT12-22	BH□□-FRT12-22-3	3/4 Female BSPT	3/4 Female BSPT																			

## B-20 Ball Valves

Basic Ordering Number		Connection Type and Size		Orifice in.(mm)		Cv		Dimensions, in. (mm)														
2-way	3-way	Connection 1	Connection 2/3	2-way	3-way	2-way	3-way	A	B	C	D	E	H									
BH□□-FRP12-22	BH□□-FRP12-22-3	3/4 Female BSPP	3/4 Female BSPP	0.71 (18.0)	0.88 (22.2)	31.0	12.0	3.59 (91.2)	1.8 (45.7)	1.25 (31.8)	2.94 (74.7)	6.00 (152)	5.45 (138)									
BH□□-FNS16-22	BH□□-FNS16-22-3	1 Female NPT	1 Female NPT					4.45 (113)	2.23 (56.6)													
BH□□-FRT16-22	BH□□-FRT16-22-3	1 Female BSPT	1 Female BSPT					5.36 (136)	2.68 (68)													
BH□□-FRP16-22	BH□□-FRP16-22-3	1 Female BSPP	1 Female BSPP					6.34 (161)	3.17 (80.5)													
BH□□-FL16-22	BH□□-FL16-22-3	1" FITOK	1" FITOK					5.36 (136)	2.68 (68)													
BH□□-FL20-22	BH□□-FL20-22-3	1 1/4" FITOK	1 1/4" FITOK					6.14 (156)	3.07 (78)													
BH□□-ML25-22	BH□□-ML25-22-3	25 mm FITOK	25 mm FITOK					3.59 (91.2)	1.80 (45.7)													
BH□□-ML28-22	BH□□-ML28-22-3	28 mm FITOK	28 mm FITOK					38.0	3.59 (91.2)					1.80 (45.7)								
BH□□-TS16-22	—	1" TS	1" TS					36.0	3.59 (91.2)					1.80 (45.7)								
BH□□-MTS25-22	—	25 mm Tube Socket Weld	25 mm Tube Socket Weld					42.0	3.59 (91.2)					1.80 (45.7)								
BH□□-PS12-22	—	3/4 PS	3/4 PS	1.13 (28.6)	0.87 (22.0)	36.0	18.0	3.46 (87.9)	1.73 (43.9)	1.25 (31.8)	1.53 (38.9)	4.03 (102)	9.14 (232)									
BH□□-PS16-22	—	1 PS	1 PS					4.39 (112)	2.19 (55.6)													
BH□□-PB16-22	—	1xSCH80 Pipe Butt Weld	1xSCH80 Pipe Butt Weld					4.57 (116)	2.28 (57.9)													
BH□□-TS20-29	—	1 1/4" TS	1 1/4" TS					90.0	4.51 (115)	2.25 (57.2)												
BH□□-PB20-32	—	1 1/4xSCH80 Pipe Butt Weld	1 1/4xSCH80 Pipe Butt Weld					100.0	4.57 (116)	2.28 (57.9)												
BH□□-FNS20-32	BH□□-FNS20-32-3	1 1/4 Female NPT	1 1/4 Female NPT					1.25 (31.8)	0.98 (25.0)	90.0				23.0	4.39 (112)	2.19 (55.6)	1.74 (44.2)	4.16 (106)	9.14 (232)	7.21 (183)		
BH□□-FNS24-32	BH□□-FNS24-32-3	1 1/2 Female NPT	1 1/2 Female NPT												100.0	4.94 (125)					2.47 (62.5)	
BH□□-TS24-32	—	1 1/2" TS	1 1/2" TS												130.0	6.14 (156)					3.12 (78)	
BH□□-PS20-32	—	1 1/4 PS	1 1/4 PS												—	—					—	
BH□□-PS24-32	—	1 1/2 PS	1 1/2 PS												—	—					—	
BH□□-PB24-32	—	1 1/2xSCH80 Pipe Butt Weld	1 1/2xSCH80 Pipe Butt Weld	—	—	—																
BH□□-FNS32-38	BH□□-FNS32-38-3	2 Female NPT	2 Female NPT	1.50 (38.1)	0.98 (25.0)	130.0	23.0				4.94 (125)	2.47 (62.5)	1.74 (44.2)		4.16 (106)	9.14 (232)					7.21 (183)	
BH□□-FRT32-38	BH□□-FRT32-38-3	2 Female BSPT	2 Female BSPT								—	—										—
BH□□-TS32-38	—	2" TS	2" TS								—	—										—
BH□□-PS32-38	—	2 PS	2 PS								—	—										—
BH□□-PB32-38	—	2xSCH80 Pipe Butt Weld	2xSCH80 Pipe Butt Weld					—	—	—												

1. FITOK means FITOK double ferrule tube fittings, TS means fractional tube socket weld, MTS means metric tube socket weld, TB means fractional tube butt weld, MTB means metric tube butt weld, PS means pipe socket weld, and PB means pipe butt weld.
2. Sizes and types listed are standard. Other sizes and types are available upon request, please contact FITOK Group or our authorized distributors.
3. Dimensions are shown with tube fitting nuts finger-tightened. All dimensions are for reference only and are subject to change. For dimensions not shown above, please contact FITOK Group or our authorized distributors.

## Ball Valves for Special Applications

### Fire safe applications

API 607 and ISO 15848-1 certified.

Patented stem packing design and seat design.

Working temperature: -40°F to 400°F (-40°C to 204°C).

Working pressure up to: 1500 psig (103 bar).

Orifice size: 0.19" (4.8 mm) to 1.25" (31.8 mm).

Helium leak rate/stem diameter  $\leq 1.78 \times 10^{-6}$  std cm<sup>3</sup>/s.

To order a fire safe valve, add -IE to the valve ordering number.

For example: BHSS-FL16-22-IE

To order a FDA-compliant fire safe valve, add -FDA-IE to the valve ordering number.

For example: BHSS-FL16-22-FDA-IE



### Structure Features

#### Live-loaded disc spring

Elastic compensation effect

#### Graphite stem packing

Maintain good sealing performance under fire conditions

#### PTFE stem packing

Maintain good sealing performance under normal conditions

#### Metal seal design

Reduce the risk of leakage under fire conditions by reducing the active gap between the spherical surface and the sealing surface

#### PTFE flange seal

Maintain good sealing performance under normal conditions

#### PTFE seat

Maintain good sealing performance under normal conditions

#### Graphite flange seal

Maintain good sealing performance under fire conditions

#### Anti-static device

Grounding spring to provide anti-static protection

#### Special bolt construction

Maintain body seal during rapid temperature changes resulting from fire exposure and water quenching

#### Vented ball

Allow pressure to equalize between the valve body and the upstream port, preventing overpressurization and potential seal blowout under fire conditions

### Pressure vs. Temperature

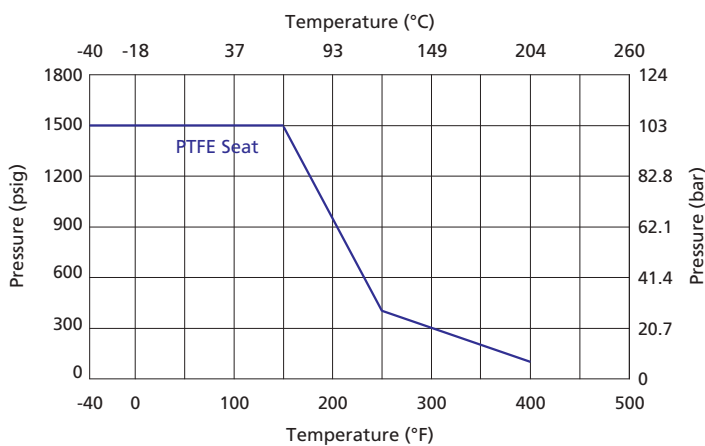

### Standard Materials of Construction

Component	Material/ ASME Specification
<i>Disc Spring</i>	<i>Alloy X-750/AMS 5542</i>
Flange Seal	Graphite
Stem Packing	Graphite
<i>Packing Support</i>	<i>316 SS/A479</i>
<i>Stem Lower Bearing</i>	<i>316 SS/A479</i>
<i>Stem Upper Bearing</i>	<i>PEEK</i>
Body Bolt	SS

Notes: Wetted components are listed in italics. Other components not listed are in the same material as components of general service ball valves. For other materials, please contact FITOK Group or our authorized distributors.

## Seal Kits

Valve Orifice	Flow Pattern	Basic Seal Kit Ordering Number	Content
05/07	2-way	BHSS-□4-RK	Seat, coned-disc spring, stem bearing, lower packing, upper packing, stem spring, gland, packing support, flange seal, instructions
	3-way		
10/13	2-way	BHSS-□8-RK	
	3-way		
22	2-way	BHSS-□16-RK	
	3-way		
29/32	2-way	BHSS-□24-RK	
	3-way		
38	2-way	BHSS-□32-RK	
	3-way		

Seat Material	Designator
PTFE	-
Reinforced PTFE	R
PEEK	P

1. Seal kit components are the same materials and grades listed in materials of construction.
2. The default seat material in the seal kit for BH series valves is PTFE. To order seats with other materials, add a seat material designator to "□" in the basic seal kit ordering number to get a complete ordering number.  
Example: BHSS-8-RK  
BHSS-P8-RK
3. The listed basic seal kit ordering numbers specify CF8M material. To order kits with other materials, such as CF8, replace "SS" with "S4" in the ordering number.  
Example: BHS4-8-RK

## Locking Device

- ⦿ Lock BH series 2-way or 3-way valves, locking hole diameters of the whole series of valves are 0.20 in (5.0 mm).
- ⦿ To order a ball valve with locking device, add -L to the valve ordering number.  
Example: BHSS-FL16-22-L/BHSS-FL16-22-3L

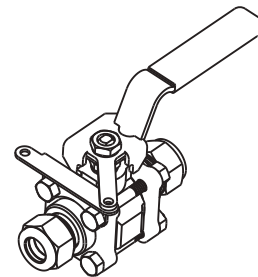

## Ball Valve without Handle

- ⦿ Ball Valve without handle can be directly connected to the FITOK actuator assembly.
- ⦿ To order, please add -AM to the valve ordering number.  
Example: BHSS-FL4-P05-AM

# Ordering Number Description

BHS4 - FNS8 - FRT8 - FL8 - P13G - OHQ3L - SCEF2

Series	Body Material	Connection 1 Type	Connection 1 Size	Connection 2/3 Type	Connection 2/3 Size	Seat Material	Orifice Size	Packing Material	Handle/Actuator	For Actuator	Flow Pattern	Locking Device	Special Application	Cleaning and Packaging
BH	SS S4 CF8M CF8	FNS Female NPT	2 1/8"	Same as Connection 1		PTFE	05 0.19" (4.8 mm)	Reinforced PTFE	I Yellow Handle Sleeve		None	L No	No	FC-01
		NS Male NPT	4 1/4" or 1/4xSCH80	Specified in the same way as Connection 1 type and size		R Reinforced PTFE	07 0.28" (7.1 mm)	G Graphite	GR Green Handle Sleeve	H Mechanical Limit Switch	N Inductive Limit Switch	L Yes	S NACE MR0175	F2 FC-02
		FRT Female BSPT	5 5/16"			P PEEK	10 0.41" (10.4 mm)		J Blue Handle Sleeve	Q Solenoid Valve			SI SilcoNert® 2000 (Sulfinert®) Coating	
		RT Male BSPT	6 3/8" or 6 mm or 3/8xSCH80				13 0.52" (13.1 mm)		AM Without Handle	HQ Mechanical Limit Switch and Solenoid Valve			CE CE Certification	
		FRP Female BSPP (for RP)	8 1/2" or 8 mm or 1/2xSCH80				22 0.88" (22.2 mm)		C 90° Normally Closed Pneumatic Actuator	NQ Inductive Limit Switch and Solenoid Valve				
		BP Male BSPP (for RG)	10 10 mm				29 1.13" (28.6 mm)		O 90° Normally Open Pneumatic Actuator			3 Straight		
		FMS Female Metric Thread (for RG-M)	12 3/4" or 12 mm or 3/4xSCH80				32 1.25" (31.8 mm)		D 90° Double Acting Pneumatic Actuator					
		MS Male Metric Thread (for RG-M)	14 14 mm or M14x1.5				38 1.50" (38.1 mm)		LX 180° Left End Normally Open Pneumatic Actuator					
		MTS Metric Tube Socket	16 1" or 16 mm or 1xSCH80						RX 180° Right End Normally Open Pneumatic Actuator					
		TS Fractional Tube Socket	18 18 mm						DX 180° Double Acting Pneumatic Actuator					
		MTB Metric Tube Butt Weld	20 1 1/4" or 20 mm or M20x1.5 or 1 1/4xSCH80						E 90° Electric Actuator					
		TB Fractional Tube Butt Weld	22 22 mm or M22x1.5						EX 180° Electric Actuator					
		PS Pipe Socket Weld	24 1 1/2" or M24x1.5 or 1-1/2xSCH80											
		PB Pipe Butt Weld	25 25 mm											
		FL Fractional Tube Fitting	27 M27x2											
		ML Metric Tube Fitting	28 28 mm											
		UFB Rotatable Fractional Tube Butt Weld	32 2" or 2xSCH80											
		UMB Rotatable Metric Tube Butt Weld												
		UPB Nut + Gasket + Pipe Bulged Nipple												
		FO Male FO Fitting												
		FR Male FR Fitting												

- Standard thread pitch for metric threads are as follows:  
M10 and below: 1 mm  
M12 to M24: 1.5 mm  
M27 and above: 2 mm  
Standard thread pitch should be omitted in the ordering number, others should be specified.
- If you need a port with orbital welding, please contact FITOK Group.
- FO means FITOK O-ring face seal fittings.  
FR means FITOK metal gasket face seal fittings.
- For oxygen-enriched environment or hazardous media service, contact FITOK Group or our authorized distributors.
- Cleaning and Packaging:  
FC-01: Standard cleaning and packaging for general industrial procedures.  
FC-02: Special cleaning and packaging for wetted system components to ensure compliance with product cleanliness requirements of ASTM G93 Level C.
- For more information about pneumatic actuator ball valves, please refer to the catalog Actuated Ball Valves.
- SilcoNert® 2000 (Sulfinert®) Coating: Except for ball valves with PEEK seat, wetted metal components SilcoNert® 2000 (Sulfinert®) coated.
- CE certification is available. For more information, please contact FITOK group or our authorized distributors

Note: "Ordering Number Description" is a reference to understand the combination rules of FITOK product part number. Not all combinations are available.

# One-Piece Instrumentation Ball Valves

## BO Series

### Features

- ⊙ Working pressure up to: 3000 psig (207 bar)
- ⊙ Working temperature: -65°F to 300°F (-54°C to 148°C)
- ⊙ End connections:  
1/4 to 1/2 thread  
1/16" to 3/4" and 3 mm to 18 mm tube fitting
- ⊙ 2-, 3-, 4-, 5-, 6- and 7-way models for on-off, switching and crossover service available
- ⊙ One-piece body and one-piece ball stem
- ⊙ No dead space
- ⊙ Top-loaded design to allow adjustment with the valve in-line
- ⊙ Thermal cycle performance improved and wear compensated by live-loaded design
- ⊙ Any reasonable connections available
- ⊙ Pneumatic and electric actuator available
- ⊙ Handle color options available
- ⊙ Full operating pressure at any port
- ⊙ Leak-tight performance testing with nitrogen or compressed air for every valve at the rated pressure to meet the requirement of no visible leak
- ⊙ The inlet can be any port except for valves with vent ports



### Notes:

1. To prevent seat leakage, packing adjustment may be required periodically during the service life of the valve.
2. A higher initial actuation torque may happen to the valves that have not been actuated for a period of time.
3. Before installation, instrumentation ball valves exposed to dynamic temperature conditions may lose their initial packing load. Stem packing adjustment should be required.

### Standard Materials of Construction

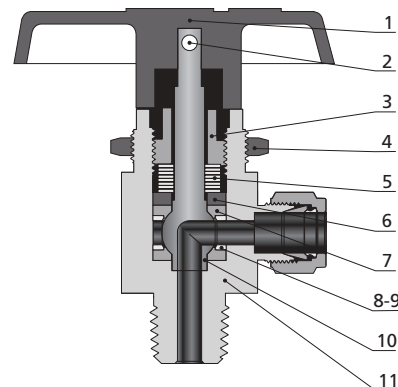
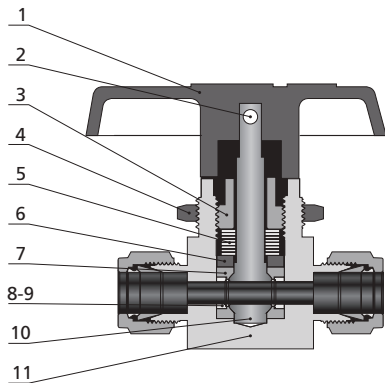

Item	Component	Valve Body Material		
		316 SS	Brass	Alloy 400
		Material Grade/ASTM Specification		
1	Handle	Nylon or Aluminium		
2	Set Screw	Zinc-plated carbon steel		
3	Packing Bolt	316 SS/A479	Brass C36000/B16	Alloy 400/B164
4	Panel Nut	316 SS/A479	Brass C36000/B16	316 SS/A479
5	Disc Spring	S17700/A693		
6	Gland	316 SS/A479	316 SS/A479	Alloy 400/B164
7	<i>Packing Seat</i>	<i>PTFE/D1710 or UHMWPE/D4020 or PFA/D3307</i>		
8	<i>Support Ring</i>	316 SS/A479	316 SS/A479	Alloy 400/B164
9	<i>Support Disc</i>			
10	<i>Ball Stem</i>	316 SS/A479	Brass C36000/B16	Alloy 400/B164
11	<i>Body</i>	316 SS/A182	Brass C37700/B283	Alloy 400/B164
<i>Wetted Lubricant</i>		<i>Fluorinated-based and silicone-based</i>		
Non-wetted Lubricant		Molybdenum disulfide with hydrocarbon binder coat		

Note: Wetted components are listed in italics.  
For other materials, please contact FITOK Group or our authorized distributors.

## On-Off (2-way) Valves

### Standard Flow Path

#### Straight Pattern



#### Angle Pattern



## Pressure vs. Temperature

Straight Pattern and Angle Pattern

PTFE Packing Seat

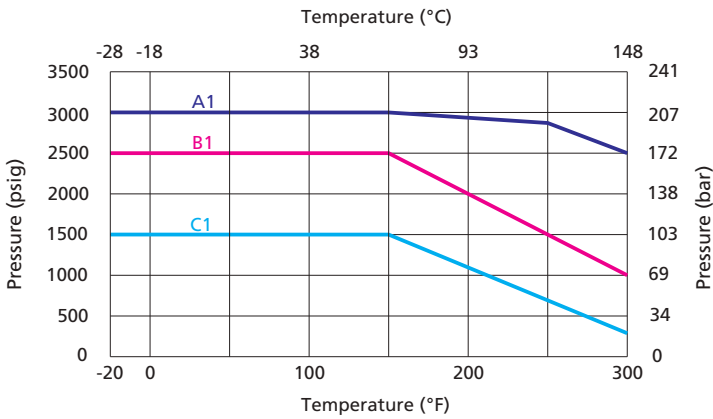

A1: Straight Pattern Valves (orifice 0.19")

B1: Straight Pattern Valves (orifice 0.05" & 0.06" & 0.09" & 0.13" & 0.28" & 0.41")

Angle Pattern Valves (orifice 0.05" & 0.06" & 0.09" & 0.13" & 0.19")

C1: Angle Pattern Valves (orifice 0.28" & 0.41")

## PFA, UHMWPE Packing Seat

The working temperature of UHMWPE packing seat should not be higher than 150°F (65°C).

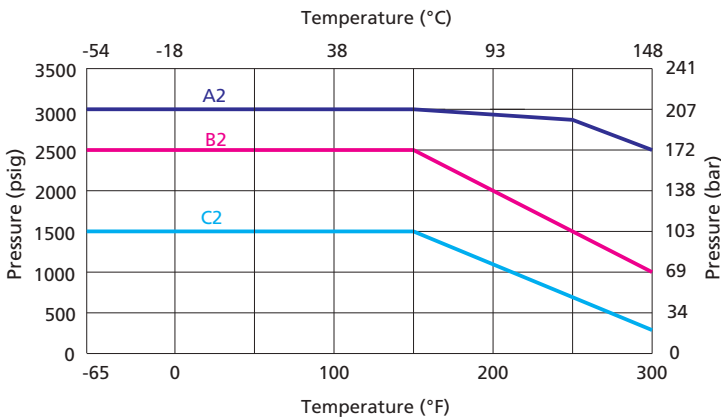

A2: Straight Pattern Valves (orifice 0.19")

B2: Straight Pattern Valves (orifice 0.05" & 0.06" & 0.09" & 0.13" & 0.28" & 0.41")

Angle Pattern Valves (orifice 0.05" & 0.06" & 0.09" & 0.13" & 0.19")

C2: Angle Valves (orifice 0.28" & 0.41")

## Dimensions

Straight Pattern

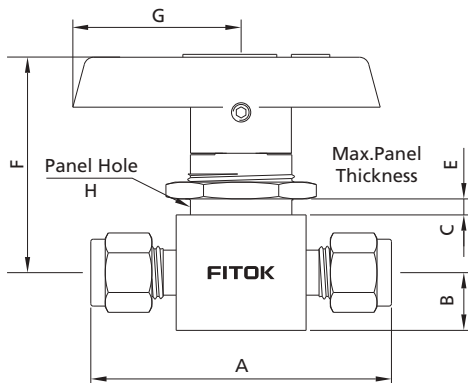

Angle Pattern

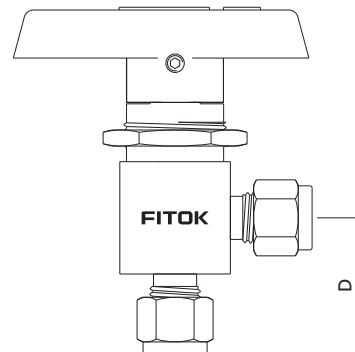

Basic Ordering Number	Connection Type and Size	Orifice in. (mm)	Cv		Dimensions, in. (mm)								
			Straight	Angle	A	B	C	D	E	F	G	H	
BO□□-FL1-00	1/16" FITOK	0.05 (1.3)	0.10	—	1.68 (42.7)				—				
BO□□-FL2-02	1/8" FITOK	0.09 (2.4)	0.20	0.15	2.01 (51.1)	0.28 (7.1)	0.34 (8.6)	0.97 (24.6)	0.25 (6.4)	1.43 (36.2)	1.10 (28)	19/32 (15.1)	
BO□□-FL4-03	1/4" FITOK	0.13 (3.2)	0.60	0.35	2.21 (56.1)			1.07 (27.2)					
BO□□-FL4-05		0.19 (4.8)	1.40	0.90	2.39 (60.7)	0.38 (9.7)	0.44 (11.2)	1.17 (29.7)	0.19 (4.8)	1.64 (41.7)	1.57 (39.9)	25/32 (19.8)	
BO□□-FL6-05	3/8" FITOK		1.50		2.58 (65.5)			1.29 (32.8)					
BO□□-FL6-07		0.28 (7.1)	6.00	2.00	3.05 (77.5)	0.56 (14.2)	0.56 (14.2)	1.43 (36.3)	0.35 (9)	2.19 (55.5)	2.05 (52)	1 1/8 (28.6)	
BO□□-FL8-10	1/2" FITOK	0.41 (10.3)	12.00	4.60	3.92 (99.6)	0.69 (17.5)	0.69 (17.5)	1.74 (44.2)	0.49 (12.5)	2.67 (67.7)	3.13 (79.6)	1 1/2 (38.1)	
BO□□-FL12-10	3/4" FITOK		6.40	3.80									
BO□□-ML3-02	3 mm FITOK	0.09 (2.4)	0.20	0.15	2.01 (51.1)	0.28 (7.1)	0.34 (8.6)	0.97 (24.6)	0.25 (6.4)	1.43 (36.2)	1.10 (28)	19/32 (15.1)	
BO□□-ML6-03	6 mm FITOK	0.13 (3.2)	0.60	0.35	2.21 (56.1)			1.07 (27.2)					
BO□□-ML6-05		0.19 (4.8)	1.40	0.90	2.39 (60.7)	0.38 (9.7)	0.44 (11.2)	1.17 (29.7)	0.19 (4.8)	1.64 (41.7)	1.57 (39.9)	25/32 (19.8)	
BO□□-ML8-05	8 mm FITOK		1.50		2.46 (62.5)			1.20 (30.5)					
BO□□-ML10-07	10 mm FITOK	0.28 (7.1)	6.00	2.00	3.07 (78.0)	0.56 (14.2)	0.56 (14.2)	1.43 (36.3)	0.35 (9)	2.19 (55.5)	2.05 (52)	1 1/8 (28.6)	
BO□□-ML12-10	12 mm FITOK	0.41 (10.3)	12.00	4.60	3.92 (99.6)	0.69 (17.5)	0.69 (17.5)	1.74 (44.2)	0.49 (12.5)	2.67 (67.7)	3.13 (79.6)	1 1/2 (38.1)	
BO□□-FNS2-03	1/8 Female NPT	0.13 (3.2)	0.50	0.30	1.63 (41.4)	0.28 (7.1)	0.34 (8.6)	0.81 (20.6)	0.25 (6.4)	1.43 (36.2)	1.10 (28)	19/32 (15.1)	
BO□□-FNS2-05		0.19 (4.8)	1.20	0.70	2.00 (50.8)	0.38 (9.7)	0.44 (11.2)	1.00 (25.4)	0.19 (4.8)	1.64 (41.7)	1.57 (39.9)	25/32 (19.8)	
BO□□-FNS4-05	1/4 Female NPT		0.90	0.75	2.06 (52.3)			1.03 (26.2)					
BO□□-FNS4-07		0.28 (7.1)	3.00	1.70	2.50 (63.5)	0.56 (14.2)	0.56 (14.2)	1.25 (31.8)	0.35 (9)	2.19 (55.5)	2.05 (52)	1 1/8 (28.6)	
BO□□-FNS6-07	3/8 Female NPT		2.60	1.50									
BO□□-FNS8-10	1/2 Female NPT	0.41 (10.3)	6.30	3.50	3.12 (79.2)	0.69 (17.5)	0.69 (17.5)	1.56 (39.6)	0.49 (12.5)	2.67 (67.7)	3.13 (79.6)	1 1/2 (38.1)	
BO□□-NS4-05	1/4 Male NPT	0.19 (4.8)	1.20	0.75	2.00 (50.8)	0.38 (9.7)	0.44 (11.2)	1.03 (26.2)	0.19 (4.8)	1.64 (41.7)	1.57 (39.9)	25/32 (19.8)	
BO□□-FRT4-05	1/4 Female BSPT		0.90			2.06 (52.3)							
BO□□-FRT6-07	3/8 Female BSPT	0.28 (7.1)	2.60	—	2.50 (63.5)	0.56 (14.2)	0.56 (14.2)	—	0.35 (9)	2.19 (55.5)	2.05 (52)	1 1/8 (28.6)	
BO□□-FRT8-10	1/2 Female BSPT	0.41 (10.3)	6.30	—	3.12 (79.2)	0.69 (17.5)	0.69 (17.5)	—	0.49 (12.5)	2.67 (67.7)	3.13 (79.6)	1 1/2 (38.1)	
BO□□-FO4-03	1/4 Male FO	0.13 (3.2)	0.60	0.35	1.75 (44.4)		0.34 (8.6)	0.94 (23.9)	0.25 (6.4)	1.43 (36.2)	1.10 (28)	19/32 (15.1)	
BO□□-FO4-05		0.19 (4.8)	2.40	0.90	1.88 (47.8)	0.38 (9.7)	0.44 (11.2)		0.19 (4.8)	1.64 (41.7)	1.57 (39.9)	25/32 (19.8)	
BO□□-FR4-03	1/4 Male FR	0.13 (3.2)	0.60	0.35	2.13 (54.1)		0.34 (8.6)	1.09 (27.7)	0.25 (6.4)	1.43 (36.2)	1.10 (28)	19/32 (15.1)	
BO□□-FR4-05		0.19 (4.8)	2.40	0.90			0.44 (11.2)		0.19 (4.8)	1.64 (41.7)	1.57 (39.9)	25/32 (19.8)	
BO□□-FR8-07	1/2 Male FR	0.28 (7.1)	6.00	—	2.88 (73.2)	0.56 (14.2)	—	—	0.35 (9)	2.19 (55.5)	2.05 (52)	1 1/8 (28.6)	
BO□□-FR8-10		0.41 (10.3)	12.00	—	3.12 (79.2)	0.69 (17.5)	—	—	0.49 (12.5)	2.67 (67.7)	3.13 (79.6)	1 1/2 (38.1)	

## Switching (3-, 4-, 5-, 6- and 7-Way) Valves

### Standard Flow Path

#### 3-way Valves



#### 4-way Valves



#### 3L Flow Path

This type of valve can connect one side port to the bottom port or shut off 3 ports. Switch between 0°, 90° and 180° positions with 180° rotation handle.

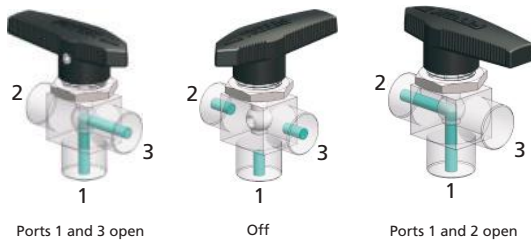

#### 4L Flow Path

This type of valve can connect one side port to the bottom port, and shut off other 2 side ports at the same time. Switching can be done in 120° increments with 360° rotation handle.



#### 5-way Valves



#### 5L Flow Path

This type of valve can connect one side port to the bottom port, and shut off other 3 side ports at the same time. Switching can be done in 90° increments with 360° rotation handle.

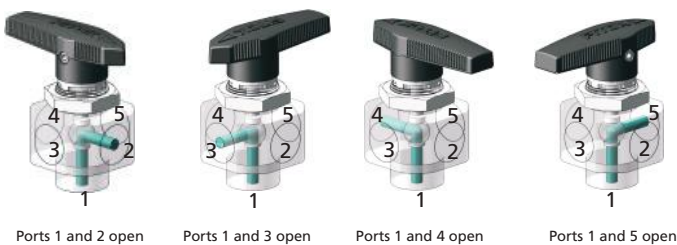

6-way Valves



6L Flow Path

This type of valve can connect one side port to the bottom port, and shut off other 4 side ports at the same time. Switching can be done in 72° increments with 360° rotation handle.



7-way Valves

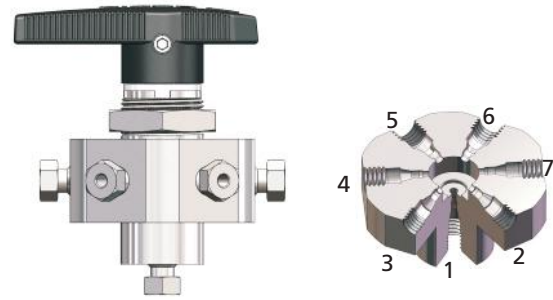

7L Flow Path

This type of valve can connect one side port to the bottom port, and shut off other 5 side ports at the same time. Switching can be done in 60° increments with 360° rotation handle.

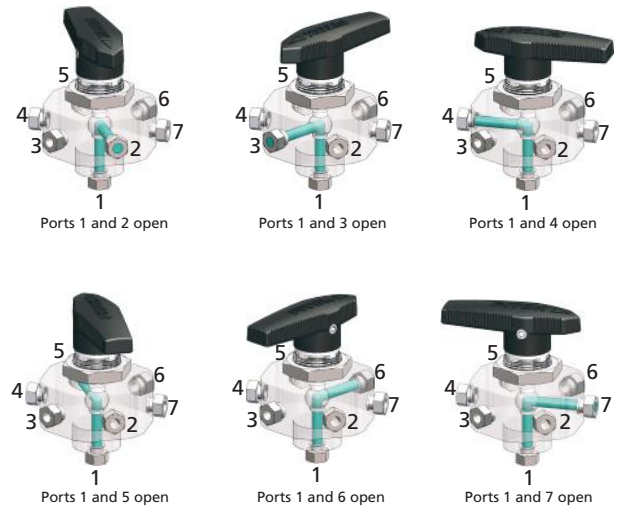

## Pressure vs. Temperature

Switching Valves

PTFE Packing Seat

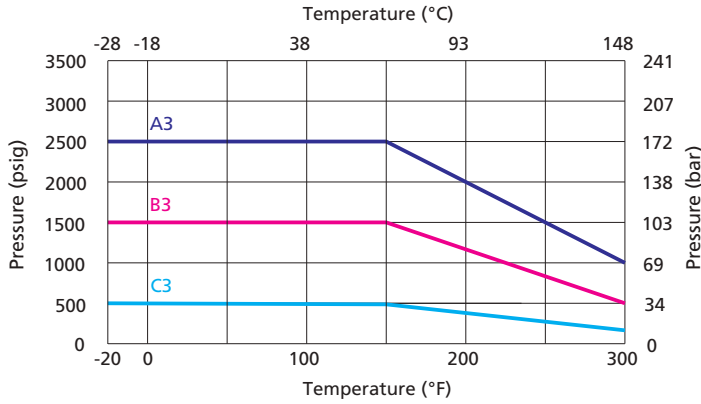

A3: 3-way (orifice 0.05" & 0.06" & 0.09" & 0.13" & 0.19")  
4-way / 5-way (orifice 0.06")

B3: 3-way (orifice 0.28" & 0.41")  
4-way / 5-way (orifice 0.41")

C3: 6-way / 7-way (orifice 0.05" & 0.06")

PFA, UHMWPE Packing Seat

The working temperature of UHMWPE packing seat should not be higher than 150°F (65°C).

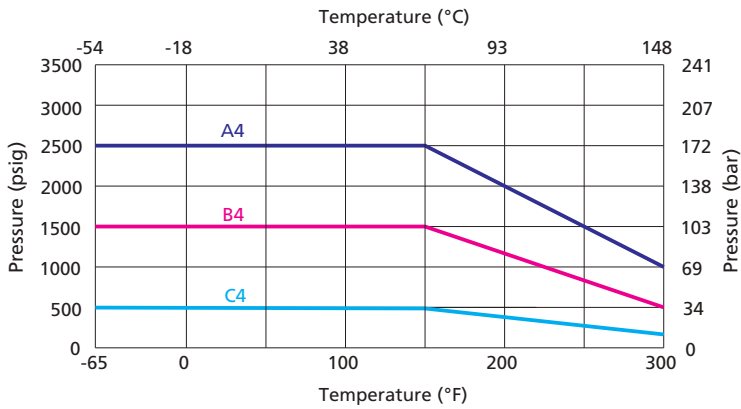

A4: 3-way (orifice 0.05" & 0.06" & 0.09" & 0.13" & 0.19")  
4-way / 5-way (orifice 0.06")

B4: 3-way (orifice 0.28" & 0.41")  
4-way / 5-way (orifice 0.41")

C4: 6-way / 7-way (orifice 0.05" & 0.06")

## Dimensions

3-way Valves

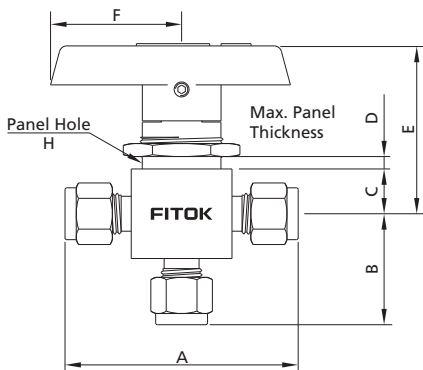

4-and 5-way Valves

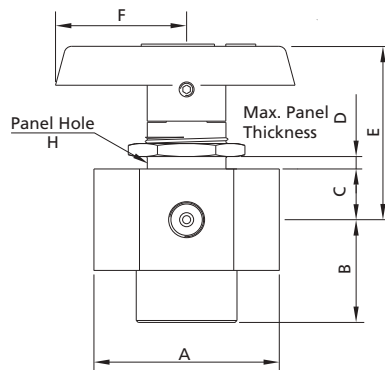

6-and 7-way Valves

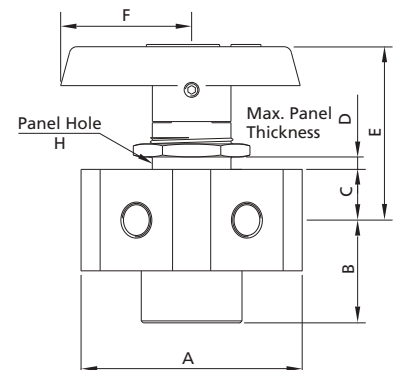

Basic Ordering Number	Connection Type and Size	Orifice in. (mm)	Cv	Dimensions, in. (mm)						
				A	B	C	D	E	F	H
<b>3-way Valves</b>										
BO□□-FL1-00-3L	1/16" FITOK	0.05 (1.3)	0.08	1.68 (42.7)	0.81 (20.6)					
BO□□-FL2-02-3L	1/8" FITOK	0.09 (2.4)	0.15	2.01 (51.1)	0.97 (24.6)	0.34 (8.6)	0.25 (6.4)	1.43 (36.2)	1.10 (28)	19/32 (15.1)
BO□□-FL4-03-3L	1/4" FITOK	0.13 (3.2)	0.35	2.21 (56.1)	1.07 (27.2)					
BO□□-FL4-05-3L		0.19 (4.8)	0.90	2.39 (60.7)	1.17 (29.7)	0.44 (11.2)	0.19 (4.8)	1.64 (41.7)	1.57 (39.9)	25/32 (19.8)
BO□□-FL6-07-3L	3/8" FITOK	0.28 (7.1)	2.00	2.89 (73.4)	1.43 (36.3)	0.56 (14.2)	0.35 (9)	2.19 (55.5)	2.05 (52)	11/8 (28.6)
BO□□-FL8-10-3L	1/2" FITOK	0.41 (10.3)	4.60	3.48 (88.4)	1.74 (44.2)	0.69 (17.5)	0.49 (12.5)	2.67 (67.7)	3.13 (79.6)	11/2 (38.1)
BO□□-FL12-10-3L	3/4" FITOK		4.90							
BO□□-ML3-02-3L	3 mm FITOK	0.09 (2.4)	0.15	2.01 (51.1)	0.97 (24.6)	0.34 (8.6)	0.25 (6.4)	1.43 (36.2)	1.10 (28)	19/32 (15.1)
BO□□-ML6-03-3L	6 mm FITOK	0.13 (3.2)	0.35	2.21 (56.1)	1.07 (27.2)					
BO□□-ML6-05-3L		8 mm FITOK	0.19 (4.8)	0.90	2.39 (60.7)	1.17 (29.7)	0.44 (11.2)	0.19 (4.8)	1.64 (41.7)	1.57 (39.9)
BO□□-ML8-05-3L	0.80			2.46 (62.5)	1.20 (30.5)					
BO□□-ML10-07-3L	10 mm FITOK	0.28 (7.1)	2.00	2.89 (73.4)	1.43 (36.3)	0.56 (14.2)	0.35 (9)	2.19 (55.5)	2.05 (52)	1 1/8 (28.6)
BO□□-ML12-10-3L	12 mm FITOK	0.41 (10.3)	4.60	3.48 (88.4)	1.74 (44.2)	0.69 (17.5)	0.49 (12.5)	2.67 (67.7)	3.13 (79.6)	1 1/2 (38.1)
BO□□-FNS2-03-3L	1/8 Female NPT	0.13 (3.2)	0.30	1.63 (41.4)	0.81 (20.6)	0.34 (8.6)	0.25 (6.4)	1.43 (36.2)	1.10 (28)	19/32 (15.1)
BO□□-FNS4-05-3L	1/4 Female NPT	0.19 (4.8)	0.75	2.06 (52.3)	1.03 (26.2)	0.44 (11.2)	0.19 (4.8)	1.64 (41.7)	1.57 (39.9)	25/32 (19.8)
BO□□-FNS4-07-3L		0.28 (7.1)	1.70	2.5 (63.5)	1.18 (30)	0.56 (14.2)	0.35 (9)	2.19 (55.5)	2.05 (52)	1 1/8 (28.6)
BO□□-FNS6-07-3L	3/8 Female NPT		1.50							
BO□□-FNS8-10-3L	1/2 Female NPT	0.41 (10.3)	3.50	3.13 (79.5)	1.56 (39.6)	0.69 (17.5)	0.49 (12.5)	2.67 (67.7)	3.13 (79.6)	1 1/2 (38.1)
BO□□-FRT4-05-3L	1/4 Female BSPT	0.19 (4.8)	0.75	2.06 (52.3)	1.03 (26.2)	0.44 (11.2)	0.19 (4.8)	1.64 (41.7)	1.57 (39.9)	25/32 (19.8)
BO□□-FRT6-07-3L	3/8 Female BSPT	0.28 (7.1)	1.50	2.5 (63.5)	1.18 (30)	0.56 (14.2)	0.35 (9)	2.19 (55.5)	2.05 (52)	1 1/8 (28.6)
BO□□-FRT8-10-3L	1/2 Female BSPT	0.41 (10.3)	3.50	3.13 (79.5)	1.56 (39.6)	0.69 (17.5)	0.49 (12.5)	2.67 (67.7)	3.13 (79.6)	1 1/2 (38.1)
<b>4 - &amp; 5-way Valves</b>										
BO□□-FL2-01-4L	1/8" Female FITOK Tube Fitting	0.06 (1.6)	0.07	2.36 (60)	1.32 (33.5)	0.44 (11.2)	0.20 (5.2)	1.76 (44.6)	1.57 (39.9)	29/32 (23.1)
BO□□-FL2-01-5L				1.85 (47)	0.88 (22.4)					
BO□□-FNS2-01-4L	1/8 Female NPT	0.06 (1.6)	0.07	1.55 (39.4)						
BO□□-FNS2-01-5L										
BO□□-FNS8-10-4L	1/2 Female NPT	0.41 (10.3)	3.50	3.13 (79.5)	1.56 (39.6)	0.69 (17.5)	0.41 (10.5)	2.67 (70.2)	2.63 (66.7)	1 1/2 (38.1)
BO□□-FNS8-10-5L										
<b>6 - &amp; 7-way Valves</b>										
BO□□-FL1-00-6L	1/16" Female FITOK Tube Fitting	0.05 (1.3)	0.05	2.64 (67)	1.32 (33.5)	0.44 (11.2)	0.28 (7)	1.76 (44.6)	1.57 (39.9)	29/32 (23.1)
BO□□-FL1-00-7L										
BO□□-FL2-01-6L	1/8" Female FITOK Tube Fitting	0.06 (1.6)	0.07	2.26 (57.6)	0.97 (24.7)					
BO□□-FL2-01-7L										

## Crossover (4-, 6-Way) Valves

### Standard Flow Path

#### 4-way Valves

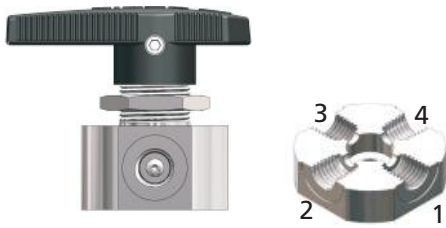

#### 6-way Valves

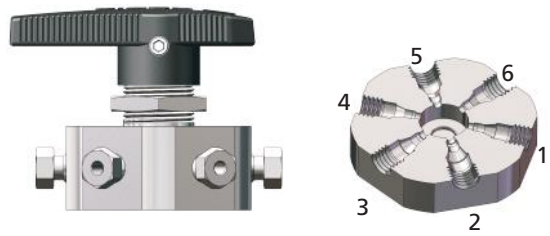

#### 4C Flow Path

This type of valve can connect two groups of adjacent ports at the same time. Switch between 0° and 90° positions with 90° rotation handle.

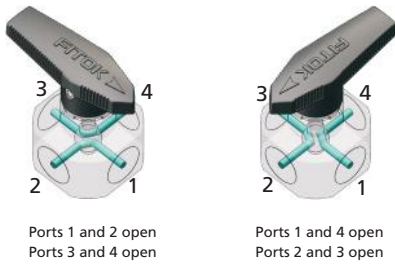

Ports 1 and 2 open  
Ports 3 and 4 open

Ports 1 and 4 open  
Ports 2 and 3 open

#### 6C Flow Path

This type of valve can connect three groups of adjacent ports at the same time. Switch between 0° and 60° positions with 60° rotation handle.

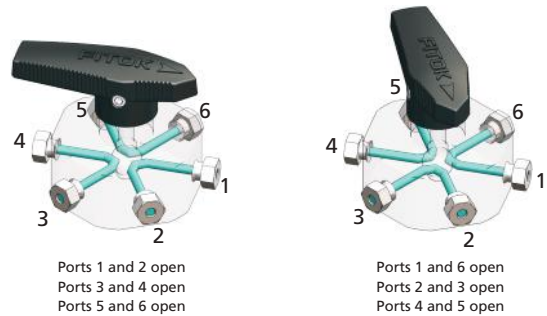

Ports 1 and 2 open  
Ports 3 and 4 open  
Ports 5 and 6 open

Ports 1 and 6 open  
Ports 2 and 3 open  
Ports 4 and 5 open

## Pressure vs. Temperature

### Crossover Valves

#### PTFE Packing Seat

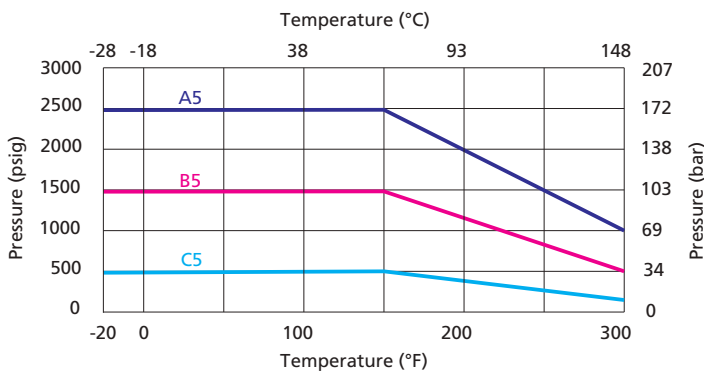

A5: 4-way (orifice 0.06")

B5: 4-way (orifice 0.41")

C5: 6-way (orifice 0.05" & 0.06")

**PFA, UHMWPE Packing Seat**

The working temperature of UHMWPE packing seat should not be higher than 150°F (65°C).

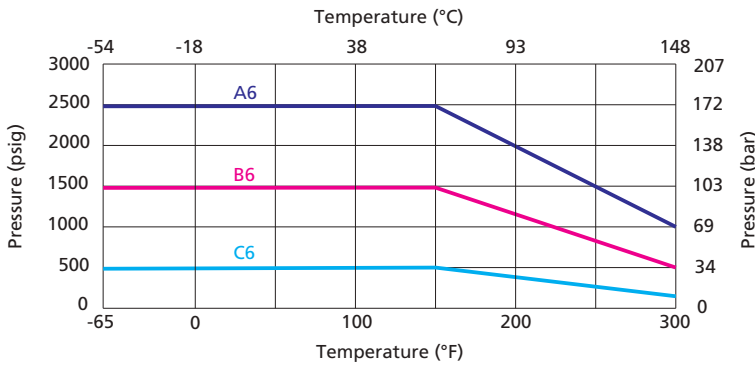

- A6: 4-way (orifice 0.06")
- B6: 6-way (orifice 0.41")
- C6: 6-way (orifice 0.05" & 0.06")

**Dimensions**

**4-way Valves**

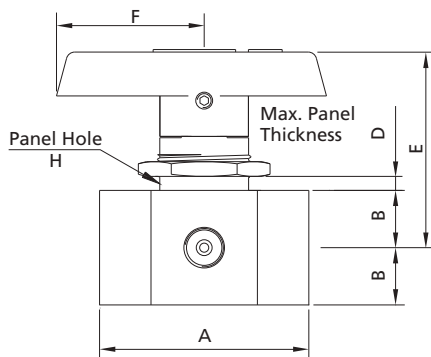

**6-way Valves**

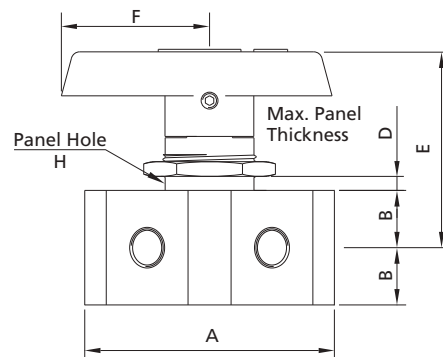

Basic Ordering Number	Connection Type and Size	Orifice in. (mm)	Cv	Dimensions, in. (mm)					
				A	B	D	E	F	H
<b>4-way Valve</b>									
BO□□-FL1-00-4C	1/16" Female FITOK Tube Fitting <sup>①</sup>	0.05 (1.3)	0.06	1.95 (49.6)					
BO□□-FL2-01-4C	1/8" Female FITOK Tube Fitting <sup>①</sup>	0.06 (1.6)	0.08	2.61 (66.3)	0.44 (11.2)	0.19 (4.8)	1.64 (41.7)	1.57 (39.9)	25/32 (19.8)
BO□□-FNS2-01-4C	1/8" Female NPT <sup>②</sup>			1.55 (39.4)					
BO□□-FNS8-07-4C	1/2" Female NPT <sup>②</sup>	0.28 (7.1)	1.60	3.13 (79.5)	0.69 (17.5)	0.48 (12.2)	2.67 (67.7)	3.13 (79.6)	1 1/2 (38.1)
<b>6-way Valve</b>									
BO□□-FL1-00-6C	1/16" Female FITOK Tube Fitting	0.05 (1.3)	0.06	1.95 (49.5)	0.44 (11.2)	0.19 (4.8)	1.68 (42.7)	1.53 (38.9)	29/32 (23.1)
BO□□-FL2-01-6C	1/8" Female FITOK Tube Fitting	0.06 (1.6)	0.08	2.59 (65.8)					

Notes: Connection type for ball valves in 4L, 5L, 6L, 7L, 4C, 6C, 4H, 4HL, 4V, 5HL, 5H and 5LV flow path is female FITOK tube fitting, which can not be used directly with standard FT and MT connections. Please contact FITOK Group or authorized distributors for use with standard FT and MT connections.

① There might be an across-connection flow during switching. If it is not acceptable to you, please specify a spherical orifice of 0.049 in. Example: BOSS-FL2-01-4C-049.

② There might be an across-connection flow during switching. If it is not acceptable to you, please specify a spherical orifice of 0.093 in. Example: BOSS-FNS8-07-4C-093.

1. FITOK means FITOK double ferrule tube fittings.
2. Sizes and types listed are standard. Other sizes and types are available upon request, please contact FITOK Group or our authorized distributors.
3. Dimensions are shown with tube fitting nuts finger-tightened. All dimensions are for reference only and are subject to change. For dimensions not shown above, please contact FITOK Group or our authorized distributors.

## Special Flow Path

### 3-way Valves



#### 3HL Flow Path

This type of valve can connect one side port to the bottom port, or connect two side ports to the bottom port. Switching can be done in 90° increments with 180° rotation handle.

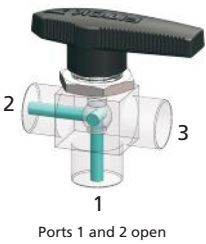
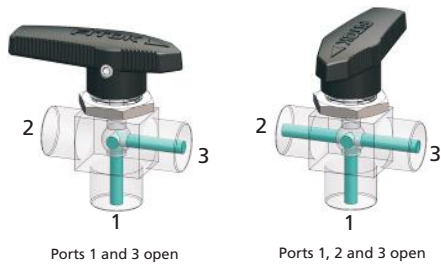

Note: For Temperature VS. Pressure curves and dimensions of 3-way valves, see Switching (3-way) Valves above. For Temperature VS. Pressure curves and dimensions of 4-way valves, see Crossover (4-way) Valves above.

### 4-way Valves



#### 4H Flow Path

This type of valve can connect two opposite ports. Switch between 0° and 90° positions with 90° rotation handle.



#### 4HL Flow Path

This type of valve can connect three adjacent ports and shut off other ports. Switching can be done in 90° increments with 360° rotation handle.

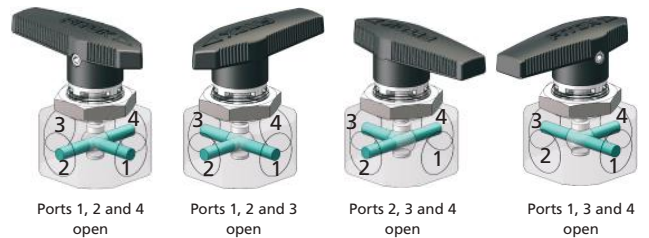

#### 4V Flow Path

This type of valve can connect two adjacent ports and shut off other ports. Switching can be done in 90° increments with 360° rotation handle.



## 5-way Valves



### 5HL Flow Path

This type of valve can connect three side ports to the bottom port, and shut off the fourth side port at the same time. Switching can be done in 90° increments with 360° rotation handle.

### 5H Flow Path

This type of valve can connect the bottom port to port 2 and port 4, or connect the bottom port to port 3 and port 5. Switch between 0° and 90° positions with 90° rotation handle.

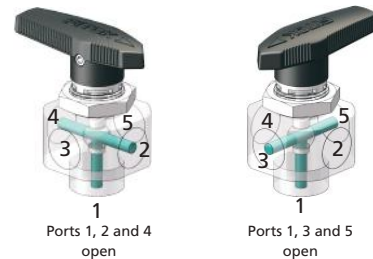
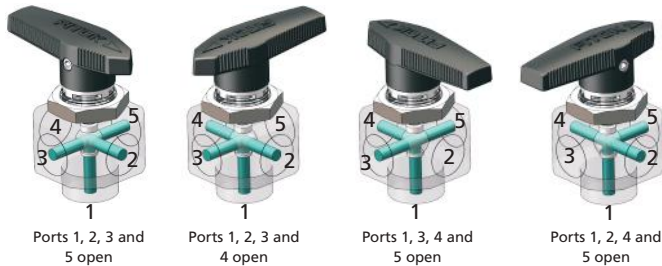

### 5LV Flow Path

This type of valve can connect two adjacent ports to the bottom port, and shut off other two side ports at the same time. Switching can be done in 90° increments with 360° rotation handle.

Note: For Temperature vs. Pressure curve and dimensions of 5-way valves, see Switching (5-way) Valves above.

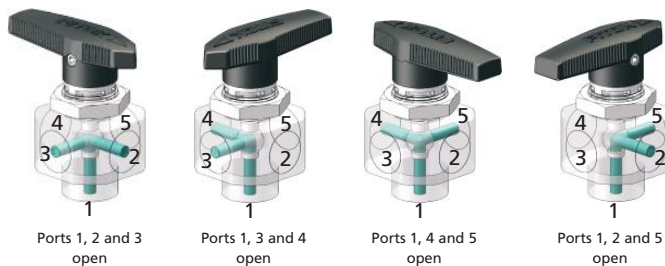

## Vent Port Options

### Vented Valves

The maximum working pressure for vented valves is 500 psig (34.4 bar).

### Straight-pattern Valves

A vent hole in the side of the valve body makes the downstream port vent to atmosphere when the valve is closed.

### Angle-pattern and 3-way Valves

A vent hole in the side of the valve body makes the bottom port vent to atmosphere when the valve is closed.

### Welded Vent Port Connections

A FITOK tube fitting or a tube stub welded to the vent port is available for stainless steel vented valves.

## Process Option

Valves with FOG process are available. FOG refers to FC-02 without lubrication.

To order a valve with FOG process, add -FOG suffix to the valve ordering number, for example: BOSS-FL4-05-FOG.

The pressure rating of valves with FOG process: 200 psig (13.8 bar) for orifice 10, 500 psig (34.4 bar) for other orifice.

The starting torque of valves with FOG process is greater than that of the lubricated valves.

## Bottom Screw Panel Mounting Options

### Mounting Dimensions

The bottom screw panel mounting options are not available on angle-pattern valves, 3-way valves, 6-way valves and 7-way valves.

#### 2-way

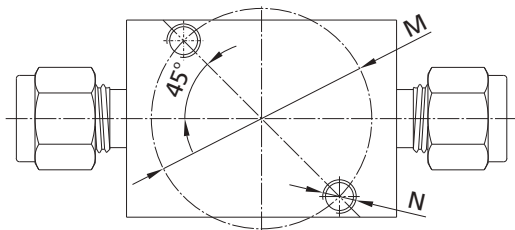

#### 4-way

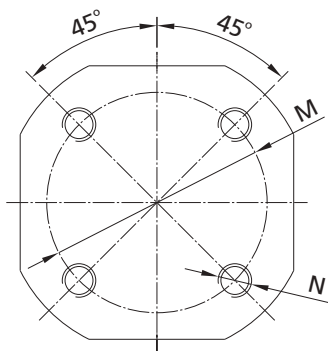

#### 5-way

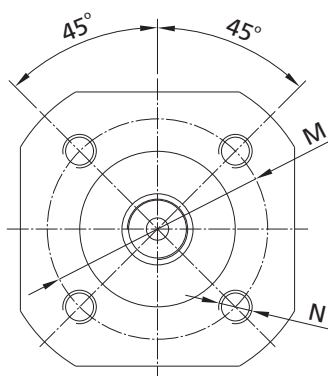

	Orifice in. (mm)	Dimensions, in. (mm)	
		M	N
2-way	0.05~0.13 (1.3~3.2)	0.63 (15.88)	M2.5 x 0.45 deep 0.24" (6)
	0.19 (4.8)	0.88 (22.23)	M3 x 0.5 deep 0.24" (6)
	0.28 (7.1)	1.25 (31.75)	M5 x 0.8 deep 0.24" (6)
4-way	0.41 (10.3)	1.63 (41.28)	M5 x 0.8 deep 0.24" (6)
	0.05~0.06 (1.3~1.6)	1.25 (31.75)	M5 x 0.8 deep 0.24" (6)
5-way	0.28 (7.1)	2.00 (50.8)	M5 x 0.8 deep 0.24" (6)
	0.05~0.06 (1.3~1.6)	1.25 (31.75)	M5 x 0.8 deep 0.24" (6)
5-way	0.41 (10.3)	2.00 (50.8)	M5 x 0.8 deep 0.24" (6)

## Locking Device

- ⊙ Locking Device 1 can lock BO series valves with 90° or 180° rotation handle, locking hole diameter is 0.21 in (5.2 mm);
- ⊙ To order a ball valve with locking device 1, add -LH to the valve ordering number.  
Example: BOSS-FL6-07-LH/BOSS-FL6-07-3L-LH
- ⊙ Locking Device 2 can lock BO series valves with 90°, 180°, or 360° rotation handle, locking hole diameter is 0.34 in (8.7 mm);
- ⊙ To order a ball valve with locking device 2, add -LK to the valve ordering number.  
Example: BOSS-ML6-05-LK/BOSS-ML6-05-5L-LK

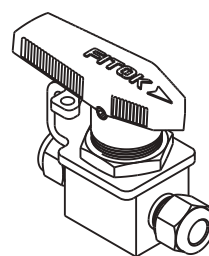

Diagram of Locking Device 1

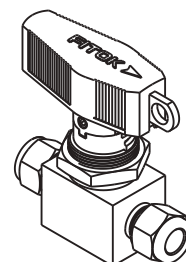

Diagram of Locking Device 2

## Ball Valve without Handle

- ⊙ Ball Valve without handle can be directly connected to the FITOK actuator assembly.
- ⊙ To order, please add -AM to the valve ordering number.  
Example: BOSS-FL4-05-AM

# Ordering Number Description

BOSS - ML6 - FL4 - ML8 - H05 - DXHQ3L - BLH - FL4 - SF2

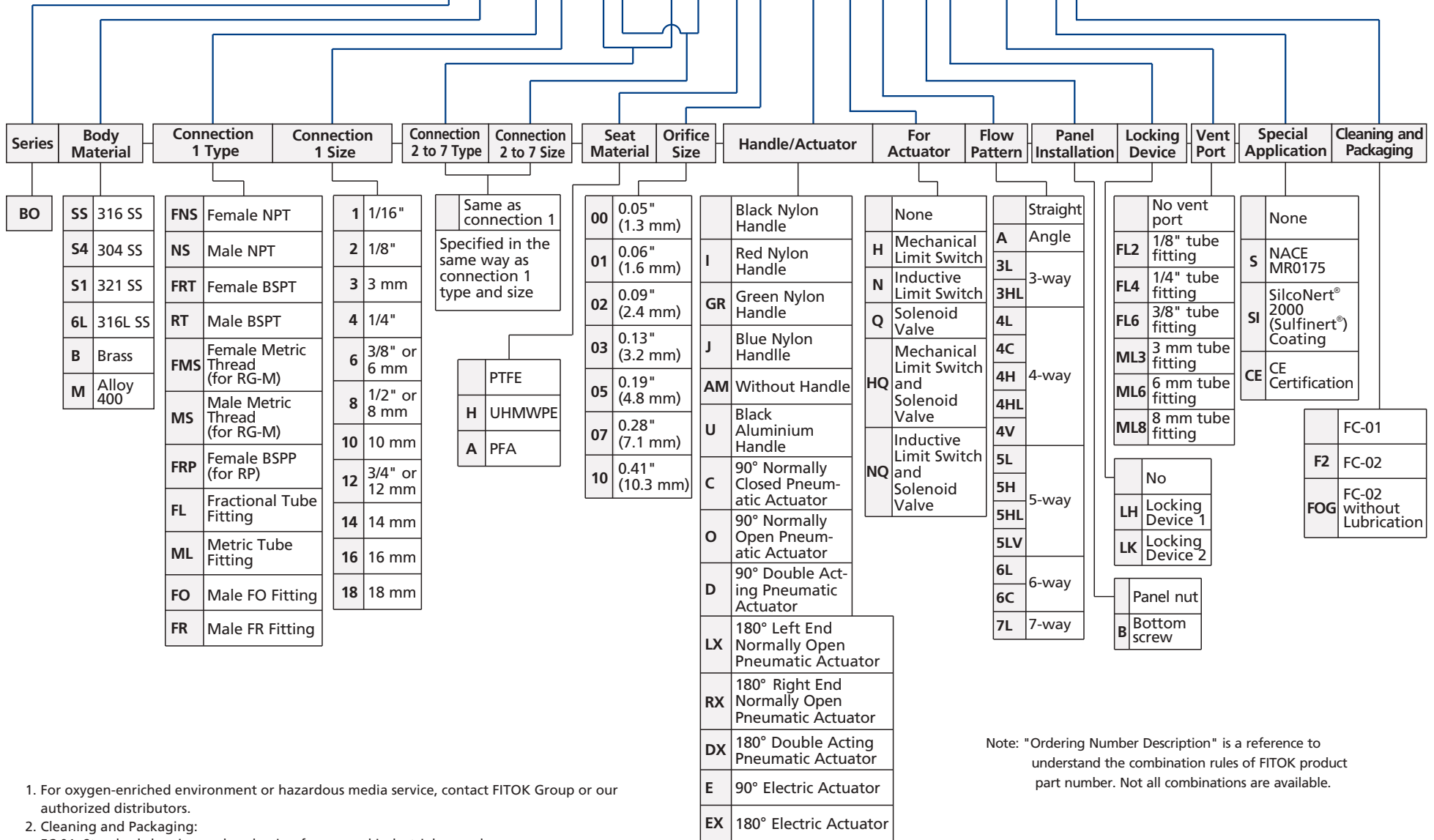

Note: "Ordering Number Description" is a reference to understand the combination rules of FITOK product part number. Not all combinations are available.

- For oxygen-enriched environment or hazardous media service, contact FITOK Group or our authorized distributors.
- Cleaning and Packaging:
  - FC-01: Standard cleaning and packaging for general industrial procedures.
  - FC-02: Special cleaning and packaging for wetted system components to ensure compliance with product cleanliness requirement of ASTM G93 Level C.
- For more information about pneumatic actuator ball valves, please refer to the catalog Actuated Ball Valves.
- SilcoNert® 2000 (Sulfinert®) Coating: Wetted metal components SilcoNert® 2000 (Sulfinert®) coated.
- CE certification is available. For more information, please contact FITOK group or our authorized distributors.

# Bar Stock Ball Valves

## BP Series

### Features

- ⊙ Working pressure up to: 10000 psig (690 bar)
- ⊙ Working temperature: -40°F to 450°F (-40°C to 232°C)
- ⊙ Bidirectional flow for 2-way valves
- ⊙ Seat wear compensation by free floating ball
- ⊙ Variety of end connections
- ⊙ Blowout proof stem with self-sealing function
- ⊙ Handle color options available
- ⊙ Optional pneumatic and electric actuator
- ⊙ Leak-tight performance testing with nitrogen or compressed air for every valve at the rated pressure (not higher than 6000 psig) to meet the requirement of no visible leak
- ⊙ Restricted flow path for BP series: only port 1 as inlet, port 2 and port 3 as outlet



Ball Valves  
Plug Valves

### Pressure vs. Temperature

#### 2-way Valves

Orifice code: 10

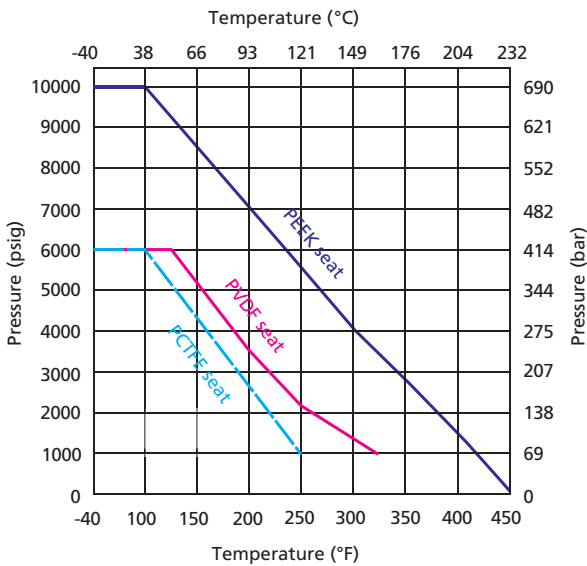

Orifice code: 13 and 19

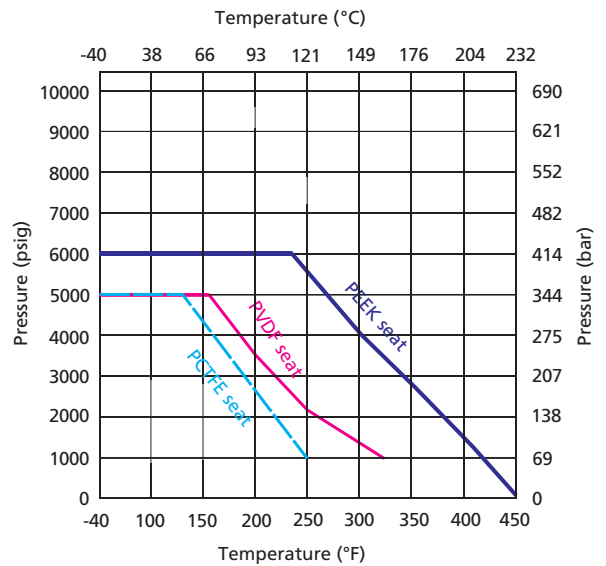

### 3-way Valves

Orifice code: 10

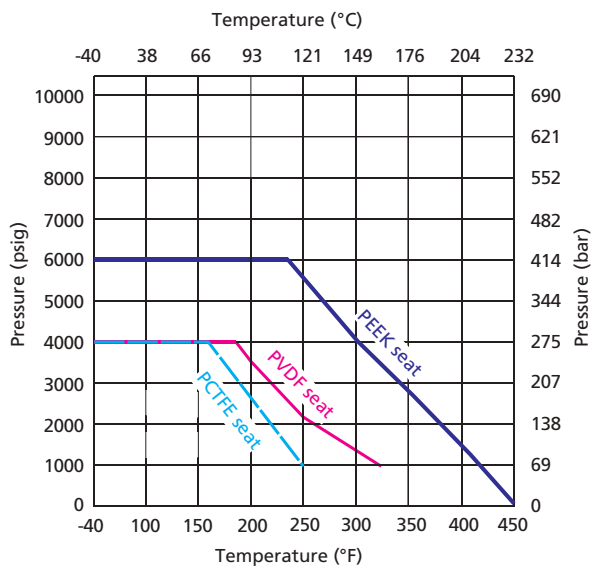

Orifice code: 13 and 19

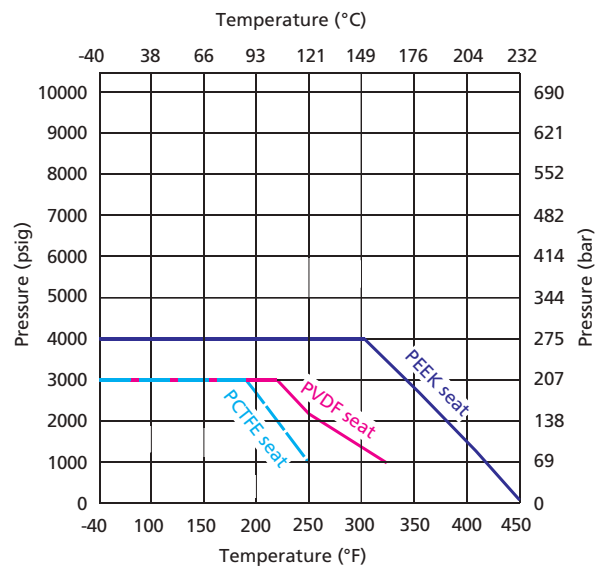

Notes: 1. Graphs are with 316 SS body. For information of body in other materials, please contact FITOK Group or our authorized distributors.  
 2. The working pressure of valves is restricted by materials of the valve body and seat, as well as end connections. When choosing a valve for your applications, please refer to the above Temperature vs. Pressure Curves and the pressure rating in the dimension table. The minimum value shall be the pressure rating of the valve.

### Standard Materials of Construction

#### 2-way Valves

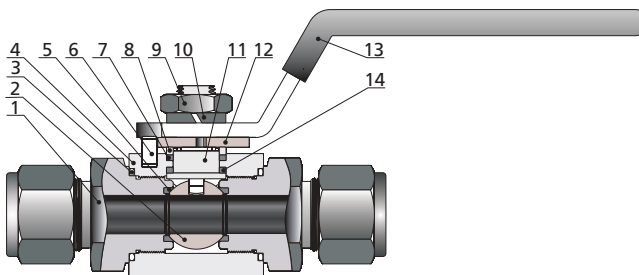

#### 3-way Valves

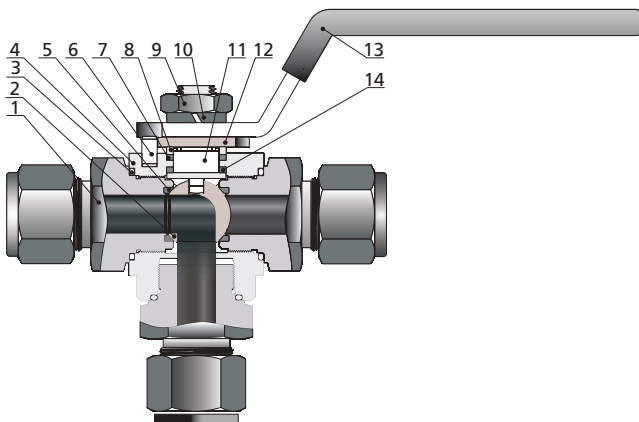

Item	Component	Body Material
		316 SS
1	<i>End Connection</i>	<i>316 SS/A479</i>
2	<i>Ball</i>	<i>316 SS/A479</i>
3	<i>O-ring</i>	<i>Fluorocarbon FKM</i>
4	<i>Body</i>	<i>316 SS/A479</i>
5	<i>Seat</i>	<i>PVDF or PCTFE or PEEK</i>
6	<i>Stop Pin</i>	SS
7	<i>Stem Packing</i>	<i>PTFE/D1710</i>
8	<i>Stem Washer</i>	316 SS/A479
9	<i>Stem Nut</i> ①	SS
10	<i>Spring Washer</i>	SS
11	<i>Stem</i>	<i>316 SS/A479</i>
12	<i>Stop Block</i>	304 SS/A240
13	<i>Handle</i>	SS with vinyl cover
14	<i>Lower Packing</i> ②	PEEK

Note: Wetted components are listed in italics.  
 For other materials, please contact FITOK Group or our authorized distributors.

- ① Ball valves with orifice code 13 or 19 have 2 stem nuts.
- ② Lower packing material of ball valves with orifice code 19 is PTFE.

Ball Valves  
Plug Valves

## Dimensions

### 2-way Valves

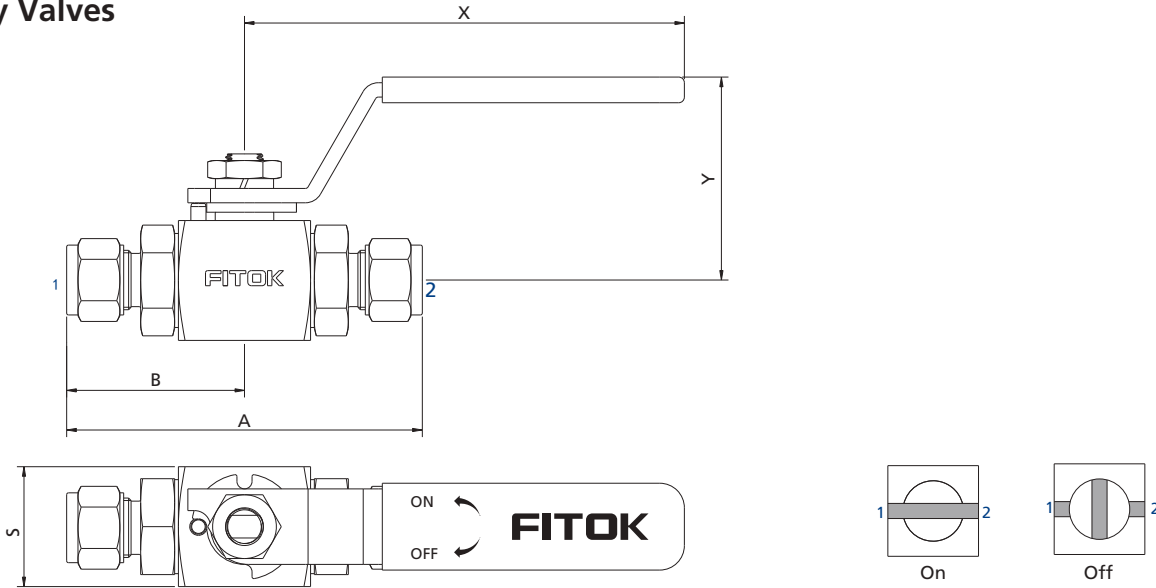

Ball Valves  
Plug Valves

Basic Ordering Number	Connection Type and Size	Pressure Rating of End Connections @ 100°F (38°C), psig (bar)	Orifice in. (mm)	Cv	Dimensions, in. (mm)				
					A	B	X	Y	S
BP□□-ML6-10	6 mm FITOK	10000 (690)	0.19(4.8)	1.2	3.54 (90.0)	1.77 (45.0)	4.57 (116.0)	2.10 (53.4)	1.30 (32.0)
BP□□-ML8-10	8 mm FITOK	7500 (517)	0.25(6.4)	2.3	3.60 (91.6)	1.80 (45.8)			
BP□□-ML10-10	10 mm FITOK	8400 (579)	0.28(7.1)	3.7	3.70 (94.0)	1.85 (47.0)			
BP□□-ML12-10	12 mm FITOK	6800 (469)	0.39 (10.0)	7.5	3.94 (100.0)	1.97 (50.0)			
BP□□-ML14-10	14 mm FITOK	6200 (427)			3.92 (99.6)	1.96 (49.8)			
BP□□-FL4-10	1/4" FITOK	10000 (690)	0.19(4.8)	1.2	3.56 (90.4)	1.78 (45.2)			
BP□□-FL6-10	3/8" FITOK	6500 (448)	0.28(7.1)	3.7	3.72 (94.6)	1.86 (47.3)			
BP□□-FL8-10	1/2" FITOK	6700 (462)	0.39 (10.0)	7.5	3.03 (77.0)	1.52 (38.5)			
BP□□-FNS4-10	1/4 Female NPT	10000 (690)			2.80 (71.0)	1.40 (35.5)			
BP□□-FNS6-10	3/8 Female NPT	10000 (690)			3.27 (83.0)	1.63 (41.5)			
BP□□-FNS8-10	1/2 Female NPT	10000 (690)			3.36 (85.4)	1.68 (42.7)			
BP□□-NS4-10	1/4 Male NPT	10000 (690)	0.28(7.1)	3.7	3.75 (95.2)	1.88 (47.6)			
BP□□-NS6-10	3/8 Male NPT	10000 (690)	0.39 (10.0)	7.5					
BP□□-NS8-10	1/2 Male NPT	10000 (690)			4.12 (104.6)	2.06 (52.3)			
BP□□-ML16-13	16 mm FITOK	5800 (400)			0.50 (12.7)	10.0	4.43 (112.6)	2.22 (56.3)	
BP□□-ML18-13	18 mm FITOK	5400 (372)					4.29 (109.0)	2.15 (54.5)	
BP□□-ML20-13	20 mm FITOK	5500 (379)	4.36 (110.6)	2.18 (55.3)					
BP□□-ML22-13	22 mm FITOK	4900 (338)	3.54 (90.0)	1.77 (45.0)					
BP□□-FL10-13	5/8" FITOK	6000 (414)	4.09 (104.0)	2.05 (52.0)					
BP□□-FL12-13	3/4" FITOK	5800 (400)	4.14 (105.2)	2.07 (52.6)					
BP□□-FNS8-13	1/2 Female NPT	6000 (414)	0.71 (18.0)	30.0			4.87 (123.8)	2.43 (61.9)	
BP□□-FNS12-13	3/4 Female NPT	6000 (414)					5.11 (129.8)	2.66 (64.9)	
BP□□-NS12-13	3/4 Male NPT	6000 (414)					4.59 (116.6)	2.29 (58.3)	
BP□□-ML20-19	20 mm FITOK	5500 (379)					5.11 (129.8)	2.66 (64.9)	
BP□□-ML22-19	22 mm FITOK	4900 (338)			3.81 (96.8)	1.91 (48.4)			
BP□□-ML25-19	25 mm FITOK	4600 (317)			4.26 (108.2)	2.13 (54.1)			
BP□□-FL12-19	3/4" FITOK	5800 (400)			4.91 (124.8)	2.45 (62.4)			
BP□□-FL16-19	1" FITOK	4700 (324)							
BP□□-FNS12-19	3/4 Female NPT	6000 (414)							
BP□□-FNS16-19	1 Female NPT	6000 (414)							
BP□□-NS16-19	1 Male NPT	6000 (414)							

### 3-way Valves

#### Vertical Pattern

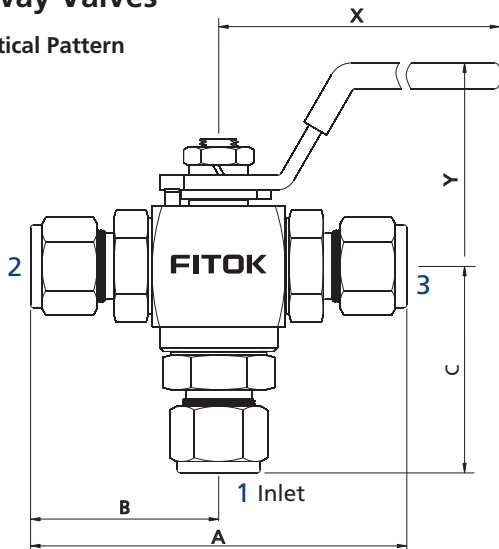

Port 1 as inlet  
180° rotation handle

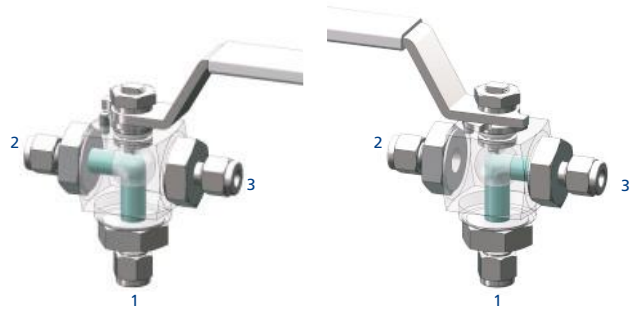

Port 1 to port 2

Port 1 to port 3

#### Horizontal Pattern

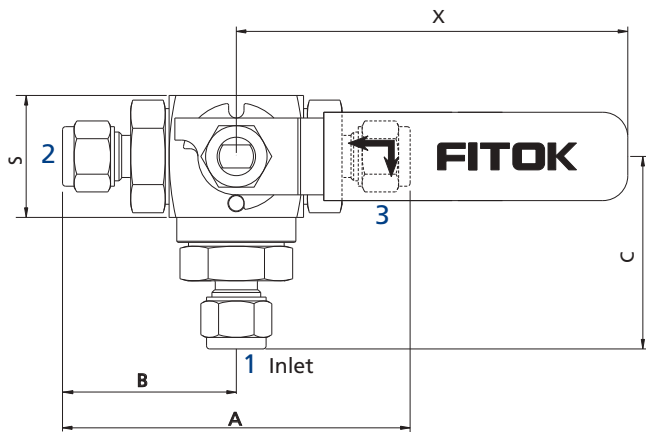

Port 1 as inlet  
90° rotation handle

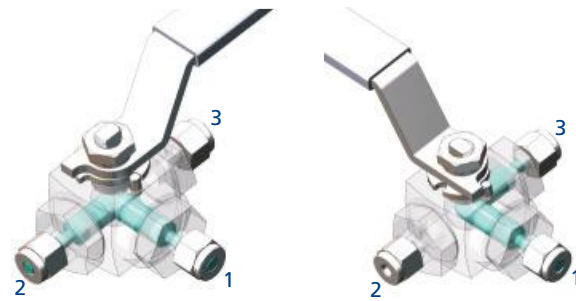

Port 1 to port 2

Port 1 to port 3

Basic Ordering Number	Connection Type and Size	Pressure Rating of End Connections @ 100 °F (38 °C), psig (bar)	Orifice in. (mm)	Dimensions, in. (mm)						
				A	B	C	X	Y	S	
BP□□-ML6-10-3□	6 mm FITOK	10000 (690)	0.19 (4.8)	3.54 (90.0)	1.77 (45.0)	2.00 (51.0)	4.57 (116.0)	2.10 (53.4)	1.30 (32.0)	
BP□□-ML8-10-3□	8 mm FITOK	7500 (517)	0.25 (6.4)	3.60 (91.6)	1.80 (45.8)	2.02 (51.3)				
BP□□-ML10-10-3□	10 mm FITOK	8400 (579)	0.28 (7.1)	3.70 (94.0)	1.85 (47.0)	2.07 (52.5)				
BP□□-ML12-10-3□	12 mm FITOK	6800 (469)	0.39 (10.0)	3.94 (100.0)	1.97 (50.0)	2.18 (55.5)				
BP□□-ML14-10-3□	14 mm FITOK	6200 (427)		3.94 (100.0)	1.97 (50.0)	2.18 (55.5)				
BP□□-FL4-10-3□	1/4" FITOK	10000 (690)	0.19 (4.8)	3.56 (90.4)	1.78 (45.2)	1.95 (49.5)				
BP□□-FL6-10-3□	3/8" FITOK	6500 (448)	0.28 (7.1)	3.72 (94.6)	1.86 (47.3)	2.16 (54.8)				
BP□□-FL8-10-3□	1/2" FITOK	6700 (462)	0.39 (10.0)	3.92 (99.6)	1.96 (49.8)	2.13 (54.0)				
BP□□-FNS4-10-3□	1/4 Female NPT	10000 (690)		3.03 (77.0)	1.52 (38.5)	1.44 (36.5)				
BP□□-FNS6-10-3□	3/8 Female NPT	10000 (690)		2.80 (71.0)	1.40 (35.5)	1.57 (40.0)				
BP□□-FNS8-10-3□	1/2 Female NPT	10000 (690)		3.27 (83.0)	1.63 (41.5)	1.83 (46.4)				
BP□□-NS4-10-3□	1/4 Male NPT	10000 (690)		0.28 (7.1)	3.36 (85.4)	1.68 (42.7)				1.90 (48.2)
BP□□-NS6-10-3□	3/8 Male NPT	10000 (690)			3.36 (85.4)	1.68 (42.7)				1.90 (48.2)
BP□□-NS8-10-3□	1/2 Male NPT	10000 (690)	3.75 (95.2)		1.88 (47.6)	2.09 (53.1)				

Ball Valves  
Plug Valves

Basic Ordering Number	Connection Type and Size	Pressure Rating of End Connections @ 100°F (38°C), psig (bar)	Orifice in. (mm)	Dimensions, in. (mm)					
	Connection 1/2/3			316 SS	A	B	C	X	Y
BP□□-ML16-13-3□	16 mm FITOK	5800 (400)	0.50 (12.7)	4.42 (112.2)	2.21 (56.1)	2.60 (66.1)	5.59 (142.0)	2.54 (64.4)	1.50 (38.0)
BP□□-ML18-13-3□	18 mm FITOK	5400 (372)		4.12 (104.6)	2.06 (52.3)	2.45 (62.3)			
BP□□-ML20-13-3□	20 mm FITOK	5500 (379)		4.43 (112.6)	2.22 (56.3)	2.61 (66.3)			
BP□□-ML22-13-3□	22 mm FITOK	4900 (338)		4.29 (109.0)	2.15 (54.5)	2.54 (64.5)			
BP□□-FL10-13-3□	5/8" FITOK	6000 (414)		4.36 (110.6)	2.18 (55.3)	2.57 (65.3)			
BP□□-FL12-13-3□	3/4" FITOK	5800 (400)		3.54 (90.0)	1.77 (45.0)	2.02 (51.2)			
BP□□-FNS8-13-3□	1/2 Female NPT	6000 (414)		4.09 (104.0)	2.05 (52.0)	2.44 (62.0)			
BP□□-FNS12-13-3□	3/4 Female NPT	6000 (414)		4.14 (105.2)	2.07 (52.6)	2.46 (62.6)			
BP□□-NS12-13-3□	3/4 Male NPT	6000 (414)							
BP□□-ML20-19-3□	20 mm FITOK	5500 (379)	0.71 (18.0)	4.87 (123.8)	2.43 (61.9)	2.89 (73.4)	6.46 (164.0)	2.72 (69.0)	1.96 (50.0)
BP□□-ML22-19-3□	22 mm FITOK	4900 (338)		5.11 (129.8)	2.66 (64.9)	3.00 (76.2)			
BP□□-ML25-19-3□	25 mm FITOK	4600 (317)		4.86 (123.4)	2.43 (61.7)	3.02 (76.7)			
BP□□-FL12-19-3□	3/4" FITOK	5800 (400)		5.11 (129.8)	2.66 (64.9)	2.85 (72.4)			
BP□□-FL16-19-3□	1" FITOK	4700 (324)		3.82 (97.0)	1.91 (48.5)	2.22 (56.5)			
BP□□-FNS12-19-3□	3/4 Female NPT	6000 (414)		4.26 (108.2)	2.13 (54.1)	2.72 (69.1)			
BP□□-FNS16-19-3□	1 Female NPT	6000 (414)		4.54 (115.2)	2.27 (57.6)	2.72 (69.1)			
BP□□-NS12-19-3□	3/4 Male NPT	6000 (414)		4.91 (124.8)	2.45 (62.4)	2.90 (73.9)			
BP□□-NS16-19-3□	1 Male NPT	6000 (414)							

1. FITOK means FITOK double ferrule tube fittings.
2. Sizes and types listed are standard. Other sizes and types are available upon request, please contact FITOK Group or our authorized distributors.
3. Dimensions are shown with tube fitting nuts finger-tightened. All dimensions are for reference only and are subject to change.  
For dimensions not shown above, please contact FITOK Group or our authorized distributors.

## Panel Mounting Options

### Dimension for Panel Mounting

Orifice in. (mm)	in. (mm)			
	L1	L2	T1	T2
0.39 (10.0)	1.02 (26.0)	1.02 (26.0)	M4×0.7P deep 0.19 (5.0)	1.18 (30.0)
0.50 (12.7)	1.18 (30.0)	1.18 (30.0)	M5×0.8P deep 0.19 (5.0)	1.18 (30.0)
0.71 (18.0)	1.37 (35.0)	1.57 (40.0)	M5×0.8P deep 0.19 (5.0)	1.50 (38.0)

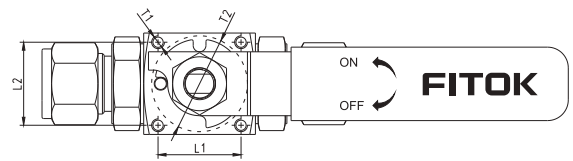

## Seal Kits

Valve Orifice	Flow Pattern	Basic Seal Kit Ordering Number	Content
10	2-way	BPSS-□10-RK	Seat, upper packing, lower packing, O-ring, stem, ball, instructions
	3-way (vertical)	BPSS-□10-3-RK	
	3-way (horizontal)	BPSS-□10-3S-RK	
13	2-way	BPSS-□13-RK	
	3-way (vertical)	BPSS-□13-3-RK	
	3-way (horizontal)	BPSS-□13-3S-RK	
19	2-way	BPSS-□19-RK	
	3-way (vertical)	BPSS-□19-3-RK	
	3-way (horizontal)	BPSS-□19-3S-RK	

Seat Material	Designator
PVDF	-
PCTFE	K
PEEK	P

1. Seal kit components are the same materials and grades listed in materials of construction.
2. The default seat material in the seal kit for BP series valves is PVDF. To order seats with other materials, add a seat material designator to "□" in the basic seal kit ordering number to get a complete ordering number.  
Example: BPSS-10-RK  
BPSS-P10-RK
3. The listed basic seal kit ordering numbers specify 316 stainless steel material. To order kits with other materials, such as 304 stainless steel material, replace "SS" with "S4" in the ordering number.  
Example: BPS4-10-RK

## Locking Device

- ⦿ Locking Device 1 can lock BP series 2-way or 3-way valves, locking hole diameter is 0.23 in (6.0 mm);
- ⦿ To order a ball valve with locking device 1, add -L to the valve ordering number.  
Example: BPSS-FL4-10-L/BPSS-FL4-10-3S-L/BPSS-FL4-10-3-L
- ⦿ Locking Device 2 can lock BP series 2-way or 3-way valves, locking hole diameters of valves with orifice 10 or 13 are 0.23 in (6.0 mm);
- ⦿ To order a ball valve with locking device 2, add -LK to the valve ordering number.  
Example: BPSS-FL4-10-LK/BPSS-FL4-10-3S-LK

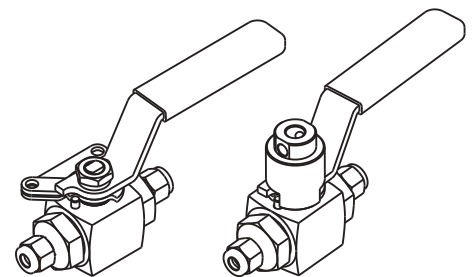

Diagram of Locking Device 1

Diagram of Locking Device 2

## Ball Valve without Handle

- ⦿ Ball Valve without handle can be directly connected to the FITOK actuator assembly.
- ⦿ To order, please add -AM to the valve ordering number.  
Example: BPSS-FL12-13-AM

# Ordering Number Description

BPSS - ML20 - FL12 - FNS8 - P13 - OHQ3ML - SCEF2

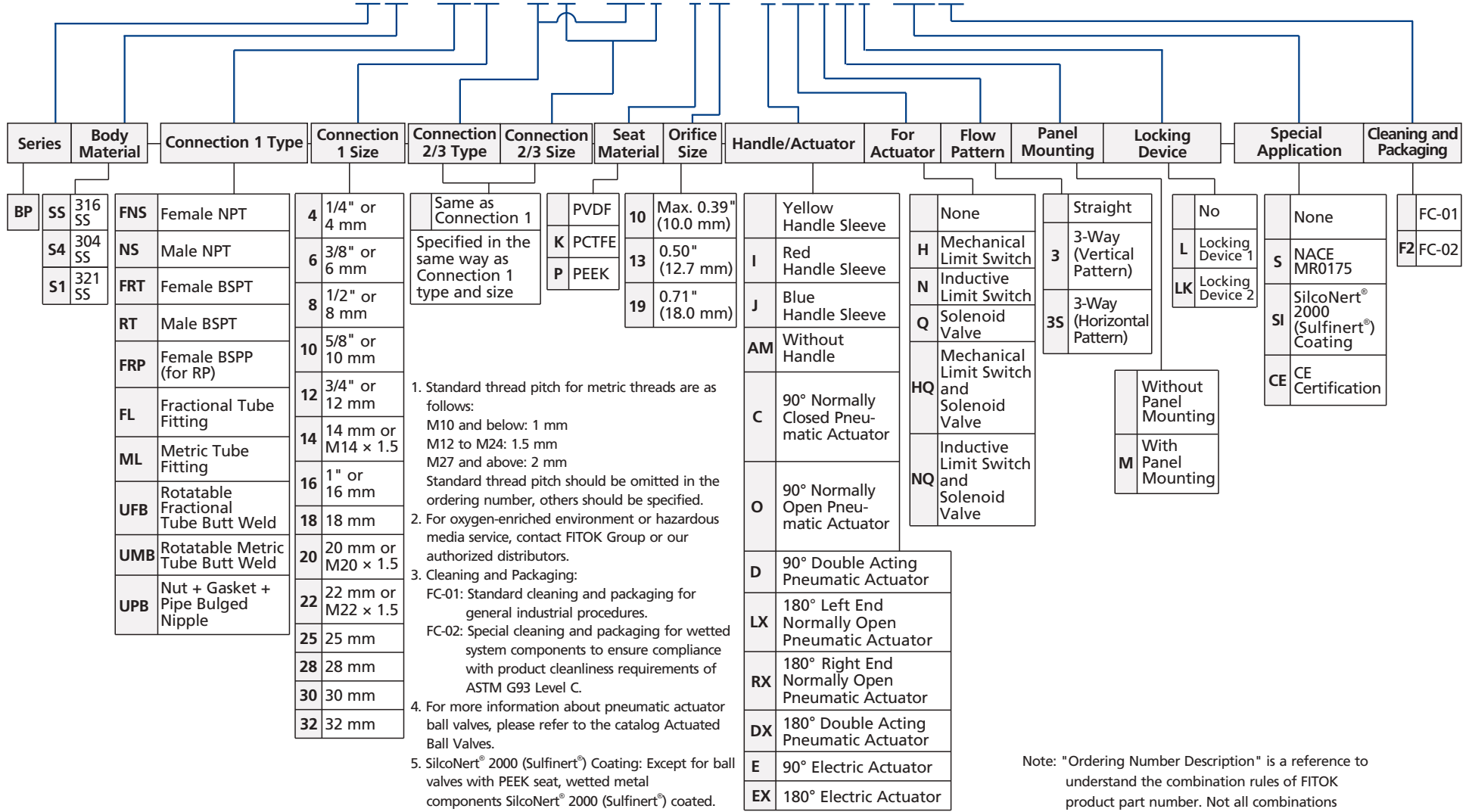

- Standard thread pitch for metric threads are as follows:  
M10 and below: 1 mm  
M12 to M24: 1.5 mm  
M27 and above: 2 mm  
Standard thread pitch should be omitted in the ordering number, others should be specified.
- For oxygen-enriched environment or hazardous media service, contact FITOK Group or our authorized distributors.
- Cleaning and Packaging:  
FC-01: Standard cleaning and packaging for general industrial procedures.  
FC-02: Special cleaning and packaging for wetted system components to ensure compliance with product cleanliness requirements of ASTM G93 Level C.
- For more information about pneumatic actuator ball valves, please refer to the catalog Actuated Ball Valves.
- SilcoNert<sup>®</sup> 2000 (Sulfinert<sup>®</sup>) Coating: Except for ball valves with PEEK seat, wetted metal components SilcoNert<sup>®</sup> 2000 (Sulfinert<sup>®</sup>) coated.
- CE certification is available. For more information, please contact FITOK group or our authorized distributors.
- The rated working pressure of BP series ball valves for "NACE MRO175" application is lower than that of standard valves. For detailed pressure values, please contact FITOK Group or our authorized distributors.

Note: "Ordering Number Description" is a reference to understand the combination rules of FITOK product part number. Not all combinations are available.

# Hex Bar Stock Ball Valves

## BR Series

### Features

- Working pressure up to 1000 psig (69.0 bar)
- Working temperature: -20°F to 450°F (-28°C to 232°C)
- Compact and economical ball valve designed for industrial applications
- Blowout-proof stem minimizes the risk of valve failure due to stem displacement or loosening
- Free-floating ball design allows the ball to be pushed against the seat by fluid pressure, ensuring a tight and reliable seal
- Bidirectional flow
- Low-torque handle enables easy and smooth operation
- A variety of end connections available
- Handle color options available
- Each valve is tested for internal and external leakage using nitrogen or compressed air at rated working pressure before shipment



### Pressure vs. Temperature

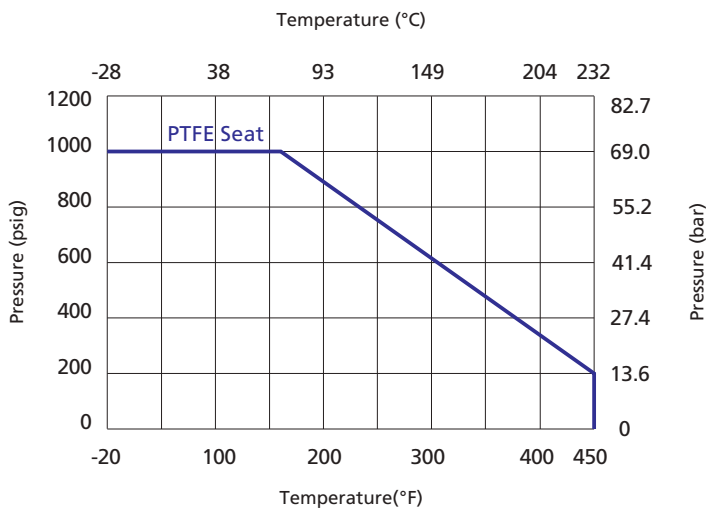

## Standard Materials of Construction

### Bar Stock Body

Ball Valves  
Plug Valves

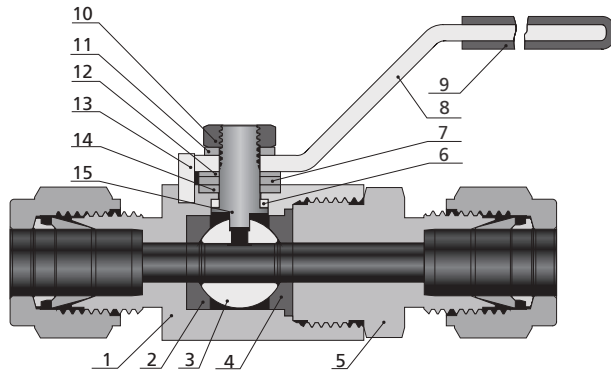

#### Handle Options



Lever Handle

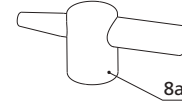

Aluminium Handle (-U)

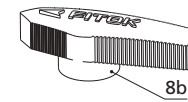

Nylon Handle (-NY)

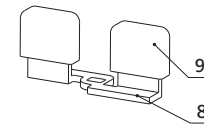

Butterfly Handle (-T)

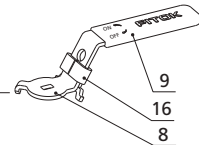

Handle with Locking Device 1 (-LB)

Item	Component	Material/Specification		
1	<i>Body</i>	<i>316 SS/A479</i>	<i>Alloy 400/B164</i>	<i>Brass C36000/B16</i>
2	<i>Front Seat</i>	<i>PTFE/D1710</i>		
3	<i>Ball</i>	<i>316 SS/A479</i>	<i>Alloy 400/B164</i>	<i>316 SS/A479</i>
4	<i>Back Seat</i>	<i>PTFE/D1710</i>		
5	<i>End Connection</i>	<i>316 SS/A479</i>	<i>Alloy 400/B164</i>	<i>Brass C36000/B16</i>
6	<i>Lower Packing</i>	<i>PTFE/D1710</i>		
7	Washer	316 SS/A479		
8	Handle	304 SS/A240		
8a		Aluminium		
8b		Nylon with 304 SS insert		
9	Sleeve	Vinyl ester		
10	Stem Nut	Stainless steel		
11	Gasket	Stainless steel		
12	Coned-disc Spring	S17700/A693		
13	Stop Pin <sup>①</sup>	Stainless steel		
14	<i>Upper Packing</i>	<i>PTFE/D1710</i>		
15	<i>Stem</i>	<i>316 SS/A479</i>	<i>Alloy 400/B164</i>	<i>316 SS/A479</i>
16	Lock Block	304 SS/A240		

Note: Wetted components are listed in italics.

① A handle with a locking device does not include a stop pin.

## Cast Body (When the valve has a handle with locking device 2)

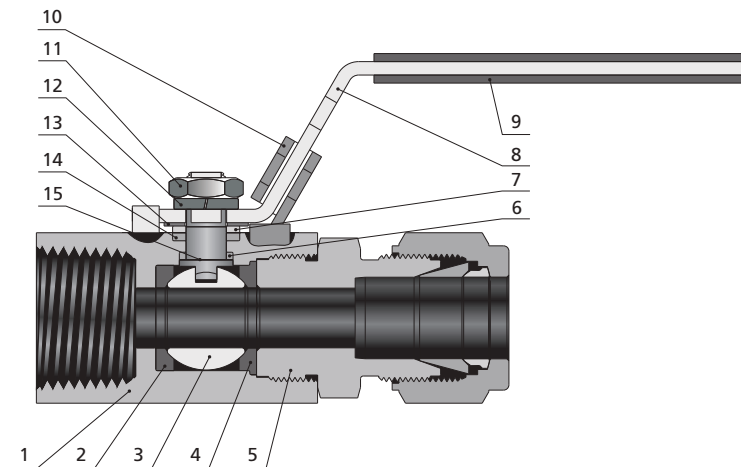

Item	Component	Material/Specification
1	<i>Body</i>	<i>CF8M/A351</i>
2	<i>Front Seat</i>	<i>PTFE/D1710</i>
3	<i>Ball</i>	<i>316 SS/A479</i>
4	<i>Back Seat</i>	<i>PTFE/D1710</i>
5	<i>End Connection</i>	<i>316 SS/A479</i>
6	<i>Lower Packing</i>	<i>PTFE/D1710</i>
7	Washer	316 SS/A479
8	Handle	304 SS/A240
9	Sleeve	Vinyl ester
10	Lock Block	304 SS/A240
11	Stem Nut	Stainless steel
12	Gasket	Stainless steel
13	Coned-disc Spring	S17700/A693
14	<i>Upper Packing</i>	<i>PTFE/D1710</i>
15	<i>Stem</i>	<i>316 SS/A479</i>

Notes: 1. Wetted components are listed in italics.

2. The standard models listed in this catalog feature a two-piece construction. However, due to the impact of connection types and orifice sizes, some models may have a three-piece construction. Please refer to the sales drawing for details.

## Dimensions

### Bar Stock Body

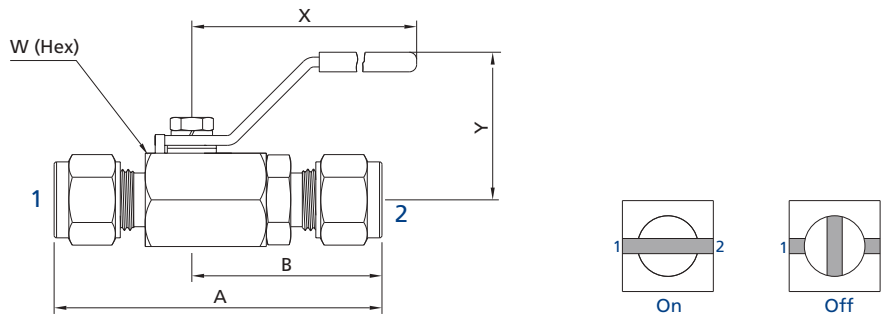

Basic Ordering Number	Connection Type and Size Connection 1/2	Orifice in. (mm)	Cv	Dimensions, in. (mm)				
				A	B	W	X	Y
BR□□-ML6-05	6 mm FITOK	0.19 (4.8)	1.25	2.57 (65.2)	1.50 (38.1)	3/4 (19.05)	2.36 (60)	1.18 (30)
BR□□-ML8-05	8 mm FITOK			2.63 (66.8)	1.53 (38.8)			
BR□□-FL4-05	1/4" FITOK			2.57 (65.2)	1.50 (38.1)			
BR□□-FL5-05	5/16" FITOK			2.63 (66.8)	1.53 (38.8)			
BR□□-FNS2-05	1/8 Female NPT			1.85 (47.0)	1.08 (27.4)			
BR□□-FRP2-05	1/8 Female BSPP			2.00 (50.0)	1.14 (29.0)			
BR□□-FRP4-05	1/4 Female BSPP			2.00 (50.0)	1.14 (29.0)			
BR□□-FNS4-05	1/4 Female NPT			1.85 (47.0)	1.08 (27.4)			
BR□□-ML10-07	10 mm FITOK	0.28 (7.1)	2.50	2.87 (72.9)	1.68 (42.7)	7/8 (22.23)	2.36 (60)	1.26 (32)
BR□□-FL6-07	3/8" FITOK			2.03 (51.6)	1.18 (30.0)			
BR□□-FRP6-07	3/8 Female BSPP			2.03 (51.6)	1.18 (30.0)			
BR□□-FNS6-07	3/8 Female NPT	0.35 (8.9)	5.30	3.15 (80.0)	1.83 (46.5)	1 1/16 (27.0)	3.15 (80)	1.54 (39)
BR□□-ML14-10	14 mm FITOK			3.24 (82.2)	1.87 (47.5)			
BR□□-FL8-10	1/2" FITOK			3.15 (80.0)	1.83 (46.5)			
BR□□-FL10-10	5/8" FITOK			3.24 (82.2)	1.87 (47.5)			
BR□□-FRP8-10	1/2 Female BSPP			2.08 (53.0)	1.12 (28.5)	15/16 (24.0)		
BR□□-FNS8-10	1/2 Female NPT			2.08 (53.0)	1.12 (28.5)			
BR□□-ML16-13	16 mm FITOK	0.47 (12.0)	8.60	3.50 (88.9)	2.00 (50.8)	1 1/4 (31.75)	3.94 (100)	2.03 (51.7)
BR□□-ML18-13	18 mm FITOK			2.48 (63.0)	1.30 (33.0)			
BR□□-FL12-13	3/4" FITOK			2.39 (60.7)	1.20 (30.5)			
BR□□-FRP12-13	3/4 Female BSPP			2.39 (60.7)	1.20 (30.5)			
BR□□-FNS12-13	3/4 Female NPT	0.63 (16.0)	17.35	3.96 (100.6)	2.24 (56.8)	1 1/2 (38.1)	3.94 (100)	2.15 (54.8)
BR□□-ML22-16	22 mm FITOK			4.31 (109.5)	2.42 (61.5)			
BR□□-ML25-16	25 mm FITOK			3.25 (82.6)	1.63 (41.3)			
BR□□-FL16-16	1" FITOK			3.00 (76.5)	1.50 (38.1)			
BR□□-FRP16-16	1 Female BSPP			3.00 (76.5)	1.50 (38.1)			
BR□□-FNS16-16	1 Female NPT			3.00 (76.5)	1.50 (38.1)			

1. FITOK means FITOK double ferrule tube fittings.
2. Sizes and types listed are standard. Other sizes and types are available upon request, please contact FITOK Group or our authorized distributors.
3. Dimensions are shown with FITOK tube fitting nuts finger-tightened. All dimensions are for reference only and are subject to change. For dimensions not shown above, please contact FITOK Group or our authorized distributors.

## Cast Body

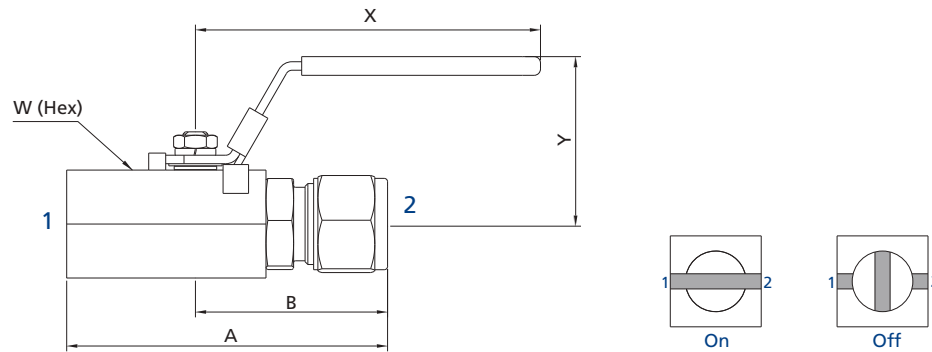

Basic Ordering Number	Connection Type and Size		Orifice in. (mm)	Cv	Dimensions, in. (mm)				
	Connection 1	Connection 2			A	B	W	X	Y
BRSS-FNS6-07-L	3/8" Female NPT	3/8" Female NPT	0.28 (7.1)	2.5	2.03 (51.6)	1.19 (30.1)	7/8 (22.23)	2.40 (61.2)	1.25 (31.8)
BRSS-FNS6-FL6-07-L	3/8" Female NPT	3/8" FITOK			2.53 (64.2)	1.68 (42.7)			
BRSS-FNS8-10-L	1/2" Female NPT	1/2" Female NPT	0.35 (8.9)	5.3	2.08 (52.8)	1.08 (27.5)	1 (25.4)	3.20 (81.2)	1.56 (39.6)
BRSS-FNS8-FL8-10-L	1/2" Female NPT	1/2" FITOK			2.78 (70.5)	1.78 (45.2)			
BRSS-FNS12-13-L	3/4" Female NPT	3/4" Female NPT	0.47 (12.0)	8.6	2.39 (60.6)	1.21 (30.6)	1 1/4 (31.75)	3.80 (96.4)	1.93 (48.9)
BRSS-FNS12-FL12-13-L	3/4" Female NPT	3/4" FITOK			3.19 (80.9)	2.00 (50.9)			
BRSS-FNS16-16-L	1" Female NPT	1" Female NPT	0.63 (16.0)	17.35	3.78 (96)	2.28 (57.8)	1 1/2 (38.1)		2.05 (52.1)
BRSS-FNS16-FL16-16-L	1" Female NPT	1" FITOK			3.92 (99.6)	2.42 (61.4)			

1. FITOK means FITOK double ferrule tube fittings.
2. Sizes and types listed are standard. Other sizes and types are available upon request, please contact FITOK Group or our authorized distributors.
3. Dimensions are shown with FITOK tube fitting nuts finger-tightened. All dimensions are for reference only and are subject to change. For dimensions not shown above, please contact FITOK Group or our authorized distributors.

## Locking Device

### Locking Device 1 (-LB)

Body Material	Orifice	Locking Hole Diameter in. (mm)	Example
A variety of optional materials (bar stock)	05	0.19 (4.8)	BRSS-ML12-10-LB
	07		
	10	0.24 (6.2)	
	13		
	16		

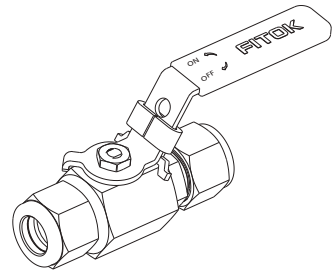

Locking Device 1

### Locking Device 2 (-L)

Body Material	Orifice	Locking Hole Diameter in. (mm)	Example
CF8M (cast)	07	0.19 (4.8)	BRSS-FNS8-10-L
	10		
	13	0.22 (5.7)	
	16		

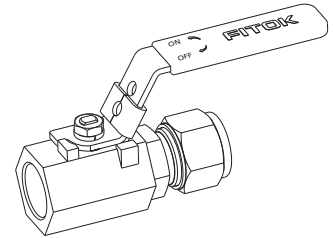

Locking Device 2

Note: The locking device is only applicable to lever handles. For other handle types requiring a locking device, please contact FITOK Group or our authorized distributors.

## Seal Kits

Valve Orifice	Basic Seal Kit Ordering Number	Content
05	BRSS-05-RK	Front seat, back seat, ball, lower packing, upper packing, instructions
07	BRSS-07-RK	
10	BRSS-10-RK	
13	BRSS-13-RK	
16	BRSS-16-RK	

1. Seal kit components are the same materials and grades listed in materials of construction.
2. The listed basic seal kit ordering numbers specify 316 stainless steel material. To order kits with other materials, such as 304 stainless steel material, replace "SS" with "S4" in the ordering number.  
Example: BRS4-05-RK

# Ordering Number Description

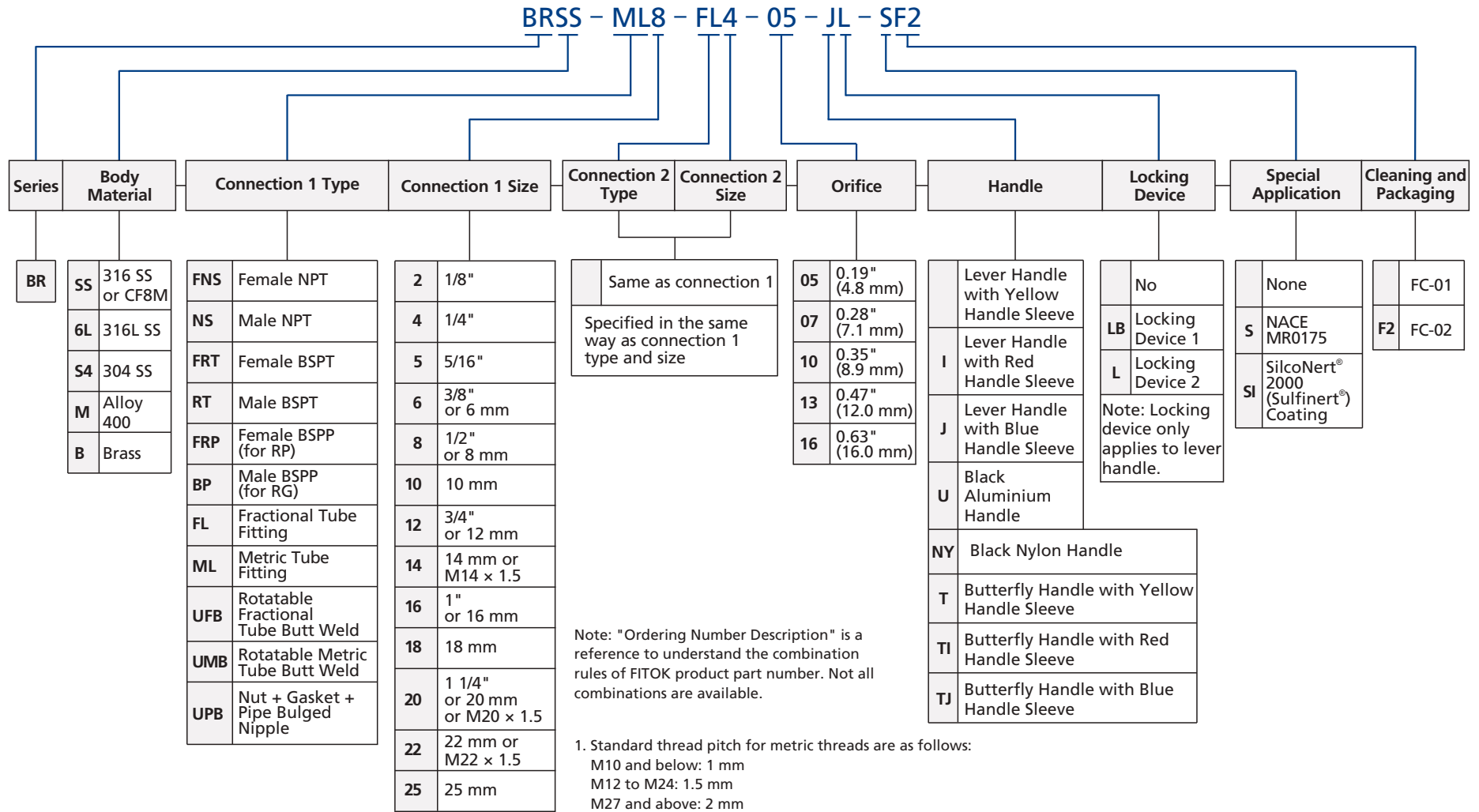

Note: "Ordering Number Description" is a reference to understand the combination rules of FITOK product part number. Not all combinations are available.

- Standard thread pitch for metric threads are as follows:  
 M10 and below: 1 mm  
 M12 to M24: 1.5 mm  
 M27 and above: 2 mm  
 Standard thread pitch should be omitted in the ordering number, others should be specified.
- For oxygen-enriched environment or hazardous media service, contact FITOK Group or our authorized distributors.
- Cleaning and Packaging:  
 FC-01: Standard cleaning and packaging for general industrial procedures.  
 FC-02: Special cleaning and packaging for wetted system components to ensure compliance with product cleaning requirement of ASTM G93 Level C.
- SilcoNert® 2000 (Sulfinert®) Coating: Wetted metal components SilcoNert® 2000 (Sulfinert®) coated.

# Hex Bar Stock Ball Valves

## BRC Series

### Features

- ⦿ Working pressure up to 2000 psig (138 bar)
- ⦿ Working temperature: -65°F to 400°F (-54°C to 204°C)
- ⦿ Compact and economical ball valve designed for industrial applications
- ⦿ Blowout-proof stem minimizes the risk of valve failure due to stem displacement or loosening
- ⦿ Free-floating ball design allows the ball to be pushed against the seat by fluid pressure, ensuring a tight and reliable seal
- ⦿ Bidirectional flow
- ⦿ Low-torque handle enables easy and smooth operation
- ⦿ A variety of end connections available
- ⦿ Handle color options available
- ⦿ Each valve is tested for internal and external leakage using nitrogen or compressed air at rated working pressure before shipment



### Pressure vs. Temperature

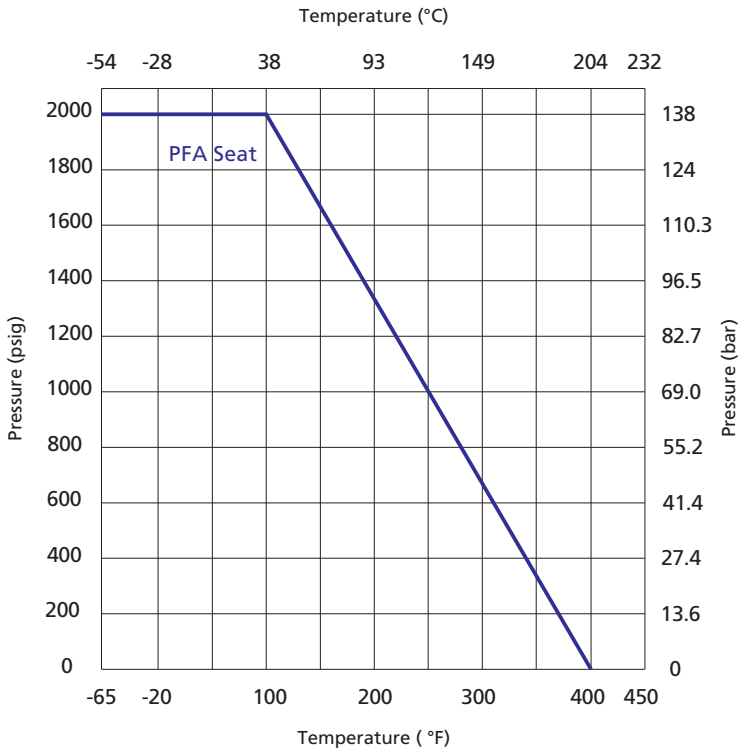

## Standard Materials of Construction

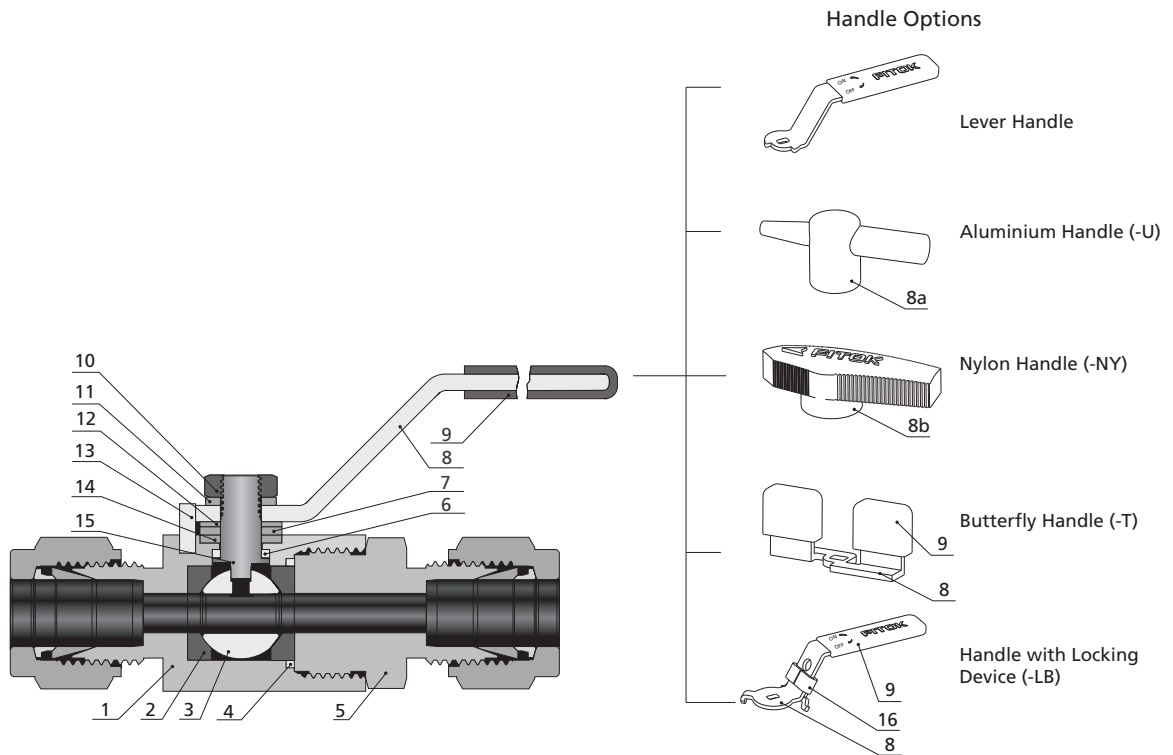

Ball Valves  
Plug Valves

Item	Component	Material/Specification	
1	<i>Body</i>	<i>316 SS/A479</i>	<i>Alloy 400/B164</i>
2	<i>Seat</i>	<i>PFA/D3307</i>	
3	<i>Ball</i>	<i>316 SS/A479</i>	<i>Alloy 400/B164</i>
4	<i>Sealing Gasket</i>	<i>316L SS/A269</i>	<i>Alloy 400/B164</i>
5	<i>End Connection</i>	<i>316 SS/A479</i>	<i>Alloy 400/B164</i>
6	<i>Lower Packing</i>	<i>PTFE/D1710</i>	
7	<i>Washer</i>	<i>316 SS/A479</i>	
8	Handle	<i>304 SS/A240</i>	
8a		Aluminium	
8b		Nylon with 304 SS insert	
9	Sleeve	Vinyl ester	
10	Stem Nut	Stainless steel	
11	Gasket	Stainless steel	
12	Coned-disc Spring	S17700/A693	
13	Stop Pin <sup>①</sup>	Stainless steel	
14	<i>Upper Packing</i>	<i>PTFE/D1710</i>	
15	<i>Stem</i>	<i>316 SS/A479</i>	<i>Alloy 400/B164</i>
16	Lock Block	304 SS/A240	

Note: Wetted components are listed in italics.

① A handle with a locking device does not include a stop pin.

## Dimensions

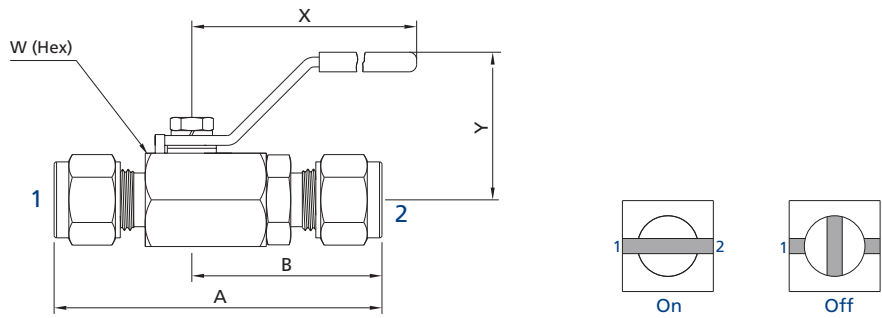

Basic Ordering Number	Connection Type and Size	Orifice in. (mm)	Cv	Dimensions, in. (mm)				
				A	B	W	X	Y
BRC□□-ML6-05	6 mm FITOK	0.19 (4.8)	1.25	2.57 (65.2)	1.50 (38.1)	3/4 (19.05)	2.36 (60)	1.18 (30)
BRC□□-ML8-05	8 mm FITOK			2.63 (66.8)	1.53 (38.8)			
BRC□□-FL4-05	1/4" FITOK			2.57 (65.2)	1.50 (38.1)			
BRC□□-FL5-05	5/16" FITOK			2.63 (66.8)	1.53 (38.8)			
BRC□□-FNS2-05	1/8 Female NPT			1.85 (47.0)	1.08 (27.4)			
BRC□□-FRP2-05	1/8 Female BSPP			2.00 (50.0)	1.14 (29.0)			
BRC□□-FRP4-05	1/4 Female BSPP			2.00 (50.0)	1.14 (29.0)			
BRC□□-FNS4-05	1/4 Female NPT			1.85 (47.0)	1.08 (27.4)			
BRC□□-ML10-07	10 mm FITOK	0.28 (7.1)	2.50	2.87 (72.9)	1.68 (42.7)	7/8 (22.23)	2.36 (60)	1.26 (32)
BRC□□-FL6-07	3/8" FITOK			2.03 (51.6)	1.18 (30.0)			
BRC□□-FRP6-07	3/8 Female BSPP			2.03 (51.6)	1.18 (30.0)			
BRC□□-FNS6-07	3/8 Female NPT	0.35 (8.9)	5.30	3.15 (80.0)	1.83 (46.5)	1 1/16 (27.0)	3.15 (80)	1.54 (39)
BRC□□-ML12-10	12 mm FITOK			3.24 (82.2)	1.87 (47.5)			
BRC□□-ML14-10	14 mm FITOK			3.15 (80.0)	1.83 (46.5)			
BRC□□-FL8-10	1/2" FITOK			3.24 (82.2)	1.87 (47.5)			
BRC□□-FL10-10	5/8" FITOK			2.08 (53.0)	1.12 (28.5)	15/16 (24.0)		
BRC□□-FRP8-10	1/2 Female BSPP			2.08 (53.0)	1.12 (28.5)			
BRC□□-FNS8-10	1/2 Female NPT	0.47 (12.0)	8.60	3.50 (88.9)	2.00 (50.8)	1 1/4 (31.75)	3.94 (100)	2.03 (51.7)
BRC□□-ML16-13	16 mm FITOK			3.13 (79.5)	1.95 (49.5)			
BRC□□-ML18-13	18 mm FITOK			3.13 (79.5)	1.95 (49.5)			
BRC□□-FL12-13	3/4" FITOK			3.96 (100.6)	2.24 (56.8)	1 1/2 (38.1)		
BRC□□-FRP12-13	3/4 Female BSPP			4.31 (109.5)	2.42 (61.5)			
BRC□□-FNS12-13	3/4 Female NPT	3.68 (93.4)	2.14 (54.3)					
BRC□□-ML22-16	22 mm FITOK	3.43 (87.1)	2.01 (51.1)					
BRC□□-ML25-16	25 mm FITOK	0.63 (16.0)	17.35	4.31 (109.5)	2.42 (61.5)	1 1/2 (38.1)	3.94 (100)	2.15 (54.8)
BRC□□-FL16-16	1" FITOK			3.68 (93.4)	2.14 (54.3)			
BRC□□-FRP16-16	1 Female BSPP			3.43 (87.1)	2.01 (51.1)			
BRC□□-FNS16-16	1 Female NPT			3.43 (87.1)	2.01 (51.1)			

1. FITOK means FITOK double ferrule tube fittings.
2. Sizes and types listed are standard. Other sizes and types are available upon request, please contact FITOK Group or our authorized distributors.
3. Dimensions are shown with FITOK tube fitting nuts finger-tightened. All dimensions are for reference only and are subject to change. For dimensions not shown above, please contact FITOK Group or our authorized distributors.

## Locking Device

### Locking Device (-LB)

Body Material	Orifice	Locking Hole Diameter in. (mm)	Example
A variety of optional materials (bar stock)	05	0.19 (4.8)	BRCSS-ML12-10-LB
	07		
	10	0.24 (6.2)	
	13		
	16		

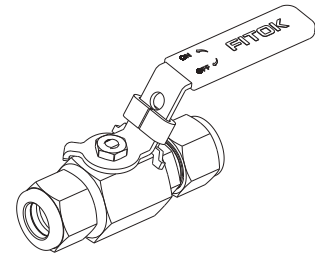

Locking Device

Note: The locking device is only applicable to lever handles. For other handle types requiring a locking device, please contact FITOK Group or our authorized distributors.

## Seal Kits

Valve Orifice	Basic Seal Kit Ordering Number	Content
05	BRCSS-05-RK	Seat, sealing gasket, ball, lower packing, upper packing, instructions
07	BRCSS-07-RK	
10	BRCSS-10-RK	
13	BRCSS-13-RK	
16	BRCSS-16-RK	

1. Seal kit components are the same materials and grades listed in materials of construction.
2. The listed basic seal kit ordering numbers specify 316 stainless steel material. To order kits with other materials, such as 304 stainless steel material, replace "SS" with "S4" in the ordering number.  
Example: BRC54-05-RK

# Ordering Number Description

**BRCSS - ML8 - FL4 - 05 - JLB - SF2**

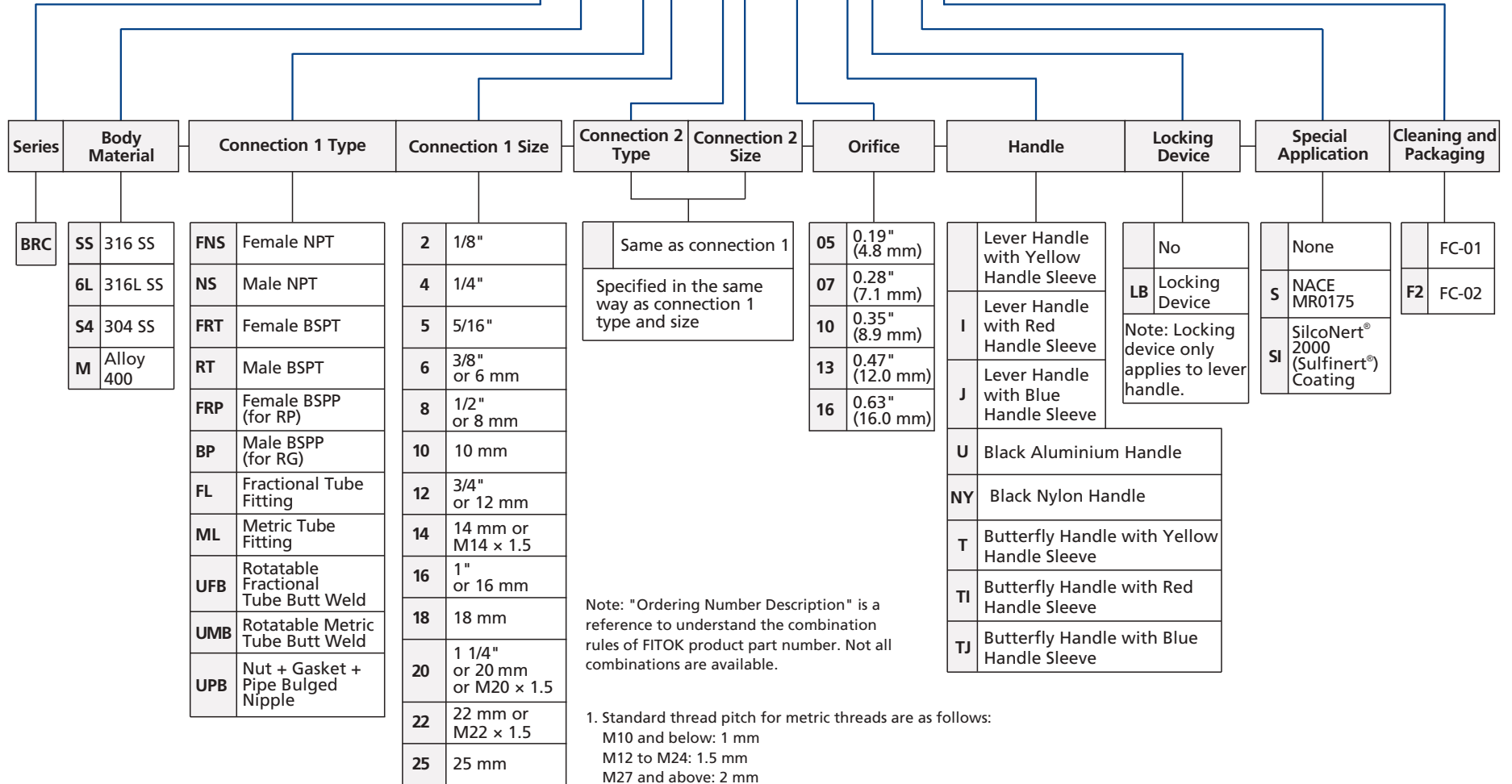

Note: "Ordering Number Description" is a reference to understand the combination rules of FITOK product part number. Not all combinations are available.

- Standard thread pitch for metric threads are as follows:  
M10 and below: 1 mm  
M12 to M24: 1.5 mm  
M27 and above: 2 mm  
Standard thread pitch should be omitted in the ordering number, others should be specified.
- For oxygen-enriched environment or hazardous media service, contact FITOK Group or our authorized distributors.
- Cleaning and Packaging:  
FC-01: Standard cleaning and packaging for general industrial procedures.  
FC-02: Special cleaning and packaging for wetted system components to ensure compliance with product cleaning requirement of ASTM G93 Level C.
- SilcoNert® 2000 (Sulfinert®) Coating: Wetted metal components SilcoNert® 2000 (Sulfinert®) coated.

# High Performance Ball Valves

## BV Series

### Features

- ⦿ Working pressure up to: 6000 psig (414 bar)
- ⦿ Working temperature: -65°F to 450°F (-54°C to 232°C)
- ⦿ Low operating torque
- ⦿ Handle as indicator of flow direction
- ⦿ Positive handle stop
- ⦿ Electric and pneumatic actuator available
- ⦿ Handle color options available
- ⦿ Leak-tight performance testing with nitrogen or compressed air for every valve to meet the requirement of no visible leakage at the rated pressure
- ⦿ Bidirectional flow for straight valves
- ⦿ The inlet of 3-way valves and angle pattern valves can only be the bottom port



Ball Valves  
Plug Valves

### Pressure vs. Temperature

#### 316 SS Body

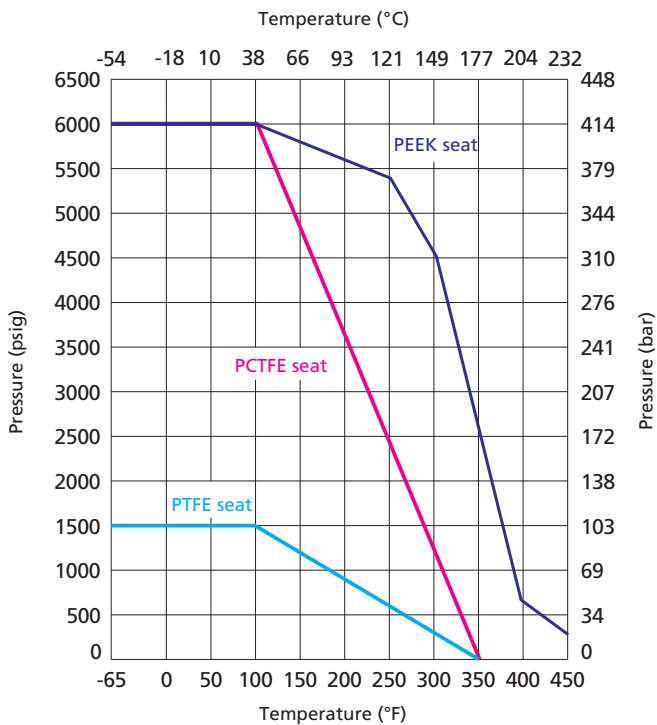

#### Brass Body

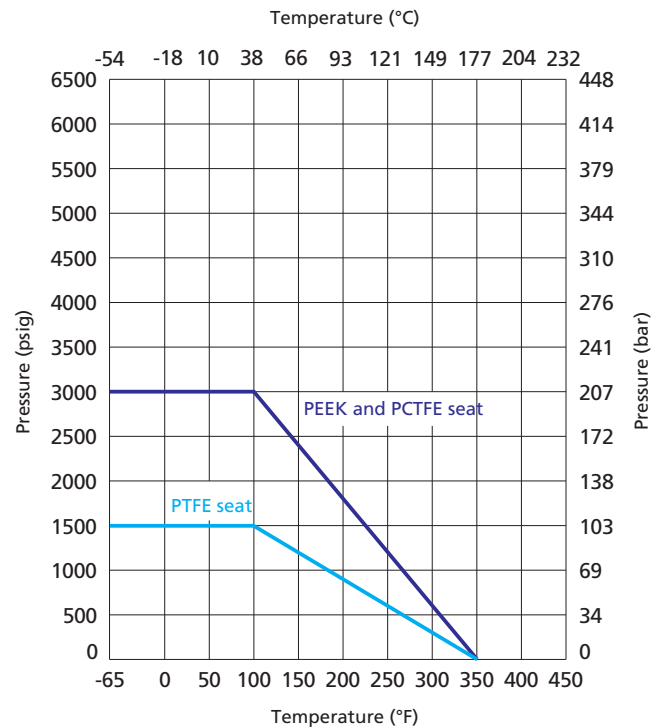

Note: The working pressure of valves is restricted by materials of the valve body and seat, as well as end connections. When choosing a valve for your applications, please refer to the above Temperature vs. Pressure Curves and the pressure rating in the dimension table. The minimum value shall be the pressure rating of the valve.

## Standard Materials of Construction

### Straight Valves

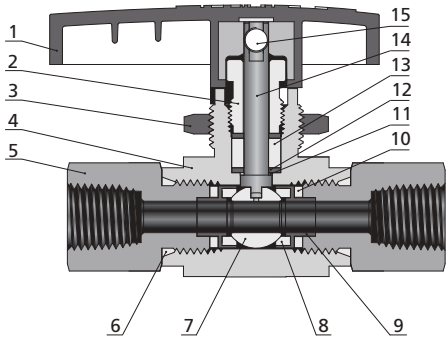

Ball Valves  
Plug Valves

Item	Component	Valve Body Material	
		SS	Brass
1	Handle	Nylon or Aluminium	
2	Packing Nut	316 SS/A479	C36000/B16
3	Panel Nut	316 SS/A479	
4	<i>Body</i>	<i>CF8M/A351</i>	<i>C37700/B283</i>
5	<i>End Connection</i>	<i>316 SS/A479</i>	<i>C36000/B16</i>
6	<i>Connection Ring</i>	PTFE	
7	<i>Ball</i>	<i>316 SS/A479</i>	
8	<i>Seat</i>	PTFE or PCTFE or PEEK	
9	<i>Seat Retainer</i>	<i>316 SS/A479</i>	
10	<i>Seat Packing</i>	PTFE	
11	<i>Stem Back-up Ring</i>	PEEK	
12	<i>Stem Washer</i>	<i>316/A479</i>	
13	<i>Stem Packing</i>	PTFE	
14	<i>Stem</i>	<i>316 SS/A479</i>	
15	Set Screw	Zinc-plated carbon steel	
	<i>Lubricants</i>	<i>Fluorinated-based</i>	

Note: Wetted components are listed in italics.  
For other materials, please contact FITOK Group or our authorized distributors.

### 3-way Valves

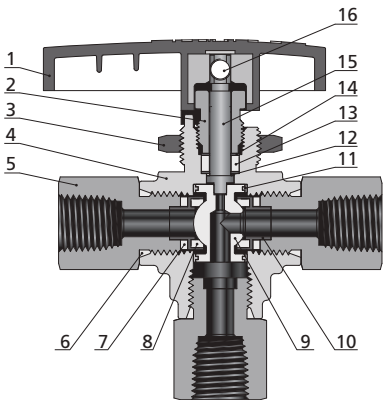

Item	Component	Valve Body Material	
		SS	Brass
1	Handle	Nylon or Aluminium	
2	Packing Nut	316 SS/A479	C36000/B16
3	Panel Nut	316 SS/A479	
4	<i>Body</i>	<i>CF8M/A351</i>	<i>C37700/B283</i>
5	<i>End Connection</i>	<i>316 SS/A479</i>	<i>C36000/B16</i>
6	<i>Connection Ring</i>	PTFE	
7	<i>Seat Packing</i>	PTFE	
8	<i>Seat</i>	PTFE or PCTFE or PEEK	
9	<i>Ball</i>	<i>316 SS/A479</i>	
10	<i>Seat Retainer</i>	<i>316 SS/A479</i>	
11	<i>Trunnion Bearing</i>	PEEK	
12	<i>Stem Back-up Ring</i>	PEEK	
13	<i>Stem Packing</i>	PTFE	
14	<i>Stem Washer</i>	<i>316 SS/A479</i>	
15	<i>Stem</i>	<i>316 SS/A479</i>	
16	Set Screw	Zinc-plated carbon steel	
	<i>Lubricants</i>	<i>Fluorinated-based</i>	

Note: Wetted components are listed in italics.  
For other materials, please contact FITOK Group or our authorized distributors.

## Angle Pattern Valves

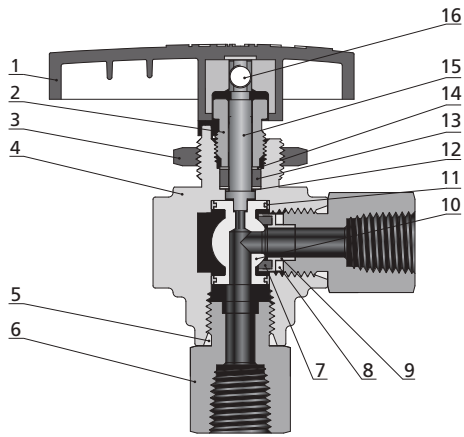

Item	Component	Valve Body Material	
		SS	Brass
1	Handle	Nylon or Aluminium	
2	Packing Nut	316 SS/A479	C36000/B16
3	Panel Nut	316 SS/A479	
4	Body	CF8M/A351	C37700/B283
5	Connection Ring	PTFE	
6	End Connection	316 SS/A479	C36000/B16
7	Seat	PTFE or PCTFE or PEEK	
8	Seat Packing	PTFE	
9	Seat Retainer	316 SS/A479	
10	Ball	316 SS/A479	
11	Trunnion Bearing	PEEK	
12	Stem Back-up Ring	PEEK	
13	Stem Packing	PTFE	
14	Stem Washer	316 SS/A479	
15	Stem	316 SS/A479	
16	Set Screw	Zinc-plated carbon Steel	
	Lubricants	Fluorinated-based	

Note: Wetted components are listed in italics.  
For other materials, please contact FITOK Group or our authorized distributors.

Ball Valves  
Plug Valves

## Dimensions

### Straight Valves

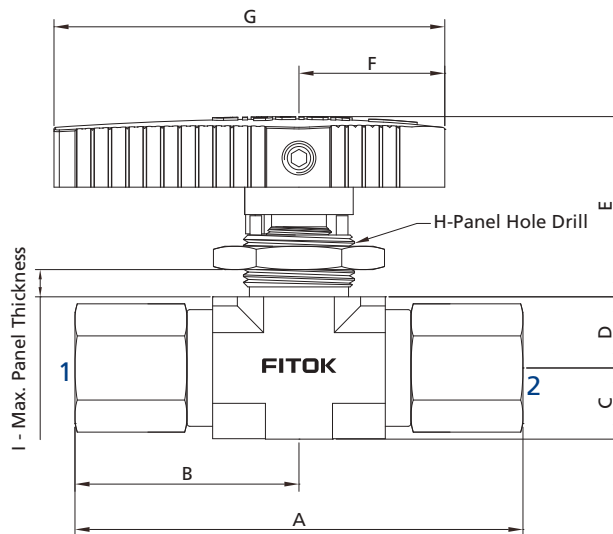

I - Max. Panel Thickness

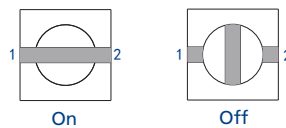

# B-60 Ball Valves

Basic Ordering Number	Connection Type and Size	Pressure Rating of End Connections @ 100°F (38°C)		Orifice in. (mm)	Cv	Dimensions, in. (mm)																					
		316 SS	Brass			A	B	C	D	E	F	G	H	I													
															Connection 1/2	316 SS	Brass										
BV□□-FL1-01	1/16" FITOK	6000 (414)	3000 (207)	0.05 (1.3)	0.06	2.60 (66.0)	1.30 (33.0)																				
BV□□-FL2-02	1/8" FITOK	6000 (414)	3000 (207)	0.09 (2.4)	0.21	2.72 (69.0)	1.36 (34.5)																				
BV□□-ML3-02	3 mm FITOK	6000 (414)	3000 (207)			2.74 (69.6)	1.37 (34.8)																				
BV□□-FRT2-04	1/8 Female BSPT	6000 (414)	3000 (207)	0.17 (4.2)	0.93	2.14 (54.4)	1.07 (27.2)	0.36 (9.2)	0.33 (8.5)	0.94 (23.9)	0.79 (20.0)	1.97 (50.0)	0.58 (14.7)	0.18 (4.6)													
BV□□-FRP2-04	1/8 Female BSPP	6000 (414)	3000 (207)																								
BV□□-FNS2-04	1/8 Female NPT	6000 (414)	3000 (207)																								
BV□□-RT2-04	1/8 Male BSPT	6000 (414)	3000 (207)																								
BV□□-BP2-04	1/8 Male BSPP	6000 (414)	3000 (207)																								
BV□□-NS2-04	1/8 Male NPT	6000 (414)	3000 (207)																								
BV□□-RT4-04	1/4 Male BSPT	6000 (414)	3000 (207)																								
BV□□-BP4-04	1/4 Male BSPP	6000 (414)	3000 (207)												2.70 (68.6)	1.35 (34.3)											
BV□□-NS4-04	1/4 Male NPT	6000 (414)	3000 (207)																								
BV□□-FL4-05	1/4" FITOK	6000 (414)	3000 (207)			0.19 (4.7)	1.04								3.48 (88.4)	1.74 (44.2)											
BV□□-ML6-05	6 mm FITOK	6000 (414)	3000 (207)												3.50 (89.0)	1.75 (44.5)											
BV□□-FL6-06	3/8" FITOK	6000 (414)	2200 (152)			0.25 (6.4)	2.34								3.60 (91.4)	1.80 (45.7)	0.48 (12.2)	0.48 (12.2)	1.24 (31.5)	0.59 (25.0)	2.64 (67.0)	0.77 (19.6)	0.25 (6.4)				
BV□□-ML8-06	8 mm FITOK	6000 (414)	2300 (159)	3.56 (90.4)	1.78 (45.2)																						
BV□□-ML10-06	10 mm FITOK	6000 (414)	1900 (131)	3.62 (92.0)	1.81 (46.0)																						
BV□□-FRT4-06	1/4 Female BSPT	6000 (414)	3000 (207)																								
BV□□-FRP4-06	1/4 Female BSPP	6000 (414)	3000 (207)					3.02 (76.8)	1.51 (38.4)																		
BV□□-FNS4-06	1/4 Female NPT	6000 (414)	3000 (207)																								
BV□□-RT4-06	1/4 Male BSPT	6000 (414)	3000 (207)																								
BV□□-BP4-06	1/4 Male BSPP	6000 (414)	3000 (207)																								
BV□□-NS4-06	1/4 Male NPT	6000 (414)	3000 (207)																								
BV□□-RT6-06	3/8 Male BSPT	6000 (414)	3000 (207)					3.24 (82.2)	1.62 (41.1)																		
BV□□-BP6-06	3/8 Male BSPP	6000 (414)	3000 (207)																								
BV□□-NS6-06	3/8 Male NPT	6000 (414)	3000 (207)																								
BV□□-FL8-10	1/2" FITOK	6000 (414)	2100 (145)	0.41 (10.3)	6.42	4.68 (118.8)	2.34 (59.4)																				
BV□□-FL12-10	3/4" FITOK	5800 (400)	1800 (124)																								
BV□□-ML12-10	12 mm FITOK	6000 (414)	2000 (138)	0.37 (9.5)	5.57																						
BV□□-ML14-10	14 mm FITOK	6000 (414)	1900 (131)	0.41 (10.3)	6.42	4.66 (118.4)	2.33 (59.2)	0.75 (19.0)	0.71 (18.0)	1.54 (39.0)	1.42 (36.0)	3.78 (96.0)	0.90 (22.9)	0.38 (9.7)													
BV□□-ML16-10	16 mm FITOK	5800 (400)	1700 (117)																								
BV□□-ML18-10	18 mm FITOK	5400 (372)	1600 (110)																								
BV□□-ML20-10	20 mm FITOK	5500 (379)	1600 (110)																								
BV□□-ML22-10	22 mm FITOK	4900 (338)	1450 (100)												4.84 (123.0)	2.42 (61.5)											
BV□□-FRT6-10	3/8 Female BSPT	6000 (414)	3000 (207)																								
BV□□-FRP6-10	3/8 Female BSPP	6000 (414)	3000 (207)												3.90 (99.0)	1.95 (49.5)											
BV□□-FNS6-10	3/8 Female NPT	6000 (414)	3000 (207)																								
BV□□-FRT8-10	1/2 Female BSPT	6000 (414)	3000 (207)												4.30 (109.2)	2.15 (54.6)											
BV□□-FRP8-10	1/2 Female BSPP	6000 (414)	3000 (207)												3.97 (101.0)	1.99 (50.5)											
BV□□-FNS8-10	1/2 Female NPT	6000 (414)	3000 (207)												4.30 (109.2)	2.15 (54.6)											
BV□□-FRT12-10	3/4 Female BSPT	6000 (414)	3000 (207)																								
BV□□-FRP12-10	3/4 Female BSPP	6000 (414)	3000 (207)			4.50 (114.2)	2.25 (57.1)																				
BV□□-FNS12-10	3/4 Female NPT	6000 (414)	3000 (207)																								
BV□□-RT8-10	1/2 Male BSPT	6000 (414)	3000 (207)																								
BV□□-BP8-10	1/2 Male BSPP	6000 (414)	3000 (207)																								
BV□□-NS8-10	1/2 Male NPT	6000 (414)	3000 (207)																								
BV□□-RT12-10	3/4 Male BSPT	6000 (414)	3000 (207)			4.44 (112.8)	2.22 (56.4)																				
BV□□-BP12-10	3/4 Male BSPP	6000 (414)	3000 (207)																								
BV□□-NS12-10	3/4 Male NPT	6000 (414)	3000 (207)																								

Ball Valves  
Plug Valves

### 3-way Valves

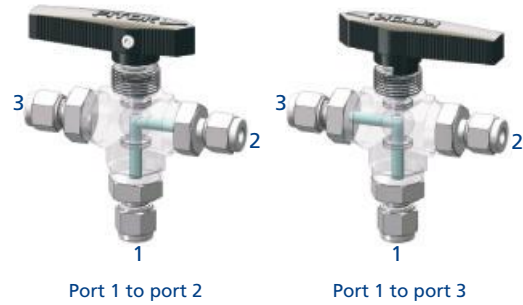
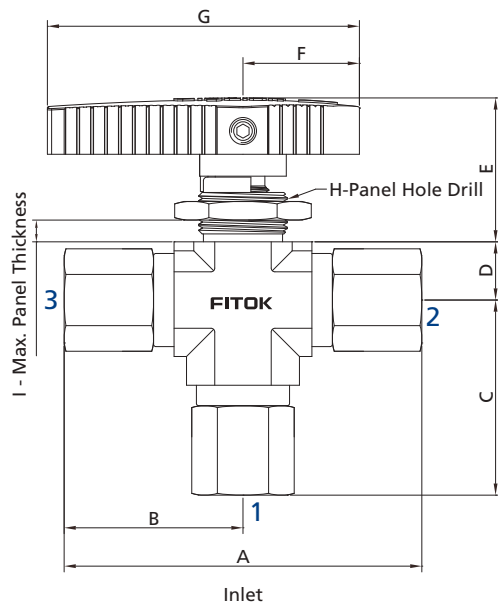

Ball Valves  
Plug Valves

Basic Ordering Number	Connection Type and Size	Pressure Rating of End Connections @ 100°F (38°C), psig (bar)		Orifice in. (mm)	Cv	Dimensions, in. (mm)													
		316 SS	Brass			A	B	C	D	E	F	G	H	I					
BV□□-FL1-01-3	1/16" FITOK	6000 (414)	3000 (207)	0.05 (1.3)	0.06	2.60 (66.0)	1.30 (33.0)	1.35 (34.3)											
BV□□-FL2-02-3	1/8" FITOK	6000 (414)	3000 (207)	0.09 (2.4)	0.21	2.72 (69.0)	1.36 (34.5)	1.41 (35.8)											
BV□□-ML3-02-3	3 mm FITOK	6000 (414)	3000 (207)			2.74 (69.6)	1.37 (34.8)	1.42 (36.1)											
BV□□-FRT2-04-3	1/8 Female BSPT	6000 (414)	3000 (207)	0.12 (3.0)	0.28	2.14 (54.4)	1.07 (27.2)	1.12 (28.5)											
BV□□-FRP2-04-3	1/8 Female BSPP	6000 (414)	3000 (207)																
BV□□-FNS2-04-3	1/8 Female NPT	6000 (414)	3000 (207)								0.33 (8.5)	0.94 (23.9)	0.79 (20.0)	1.97 (50.0)	0.58 (14.7)	0.18 (4.6)			
BV□□-RT2-04-3	1/8 Male BSPT	6000 (414)	3000 (207)			2.36 (60.0)	1.18 (30.0)	1.23 (31.3)											
BV□□-BP2-04-3	1/8 Male BSPP	6000 (414)	3000 (207)																
BV□□-NS2-04-3	1/8 Male NPT	6000 (414)	3000 (207)																
BV□□-RT4-04-3	1/4 Male BSPT	6000 (414)	3000 (207)																
BV□□-BP4-04-3	1/4 Male BSPP	6000 (414)	3000 (207)																
BV□□-NS4-04-3	1/4 Male NPT	6000 (414)	3000 (207)																
BV□□-FL4-05-3	1/4" FITOK	6000 (414)	3000 (207)			0.19 (4.7)	0.70	3.48 (88.4)	1.74 (44.2)	1.88 (47.7)									
BV□□-ML6-05-3	6 mm FITOK	6000 (414)	3000 (207)	3.50 (89.0)	1.75 (44.5)			1.89 (48.0)											
BV□□-FL6-05-3	3/8" FITOK	6000 (414)	3000 (207)	3.60 (91.4)	1.80 (45.7)			1.94 (49.2)											
BV□□-ML8-05-3	8 mm FITOK	6000 (414)	3000 (207)	3.56 (90.4)	1.78 (45.2)			1.92 (48.7)											
BV□□-ML10-05-3	10 mm FITOK	6000 (414)	3000 (207)	3.62 (92.0)	1.81 (46.0)			1.95 (49.5)											
BV□□-FRT4-05-3	1/4 Female BSPT	6000 (414)	3000 (207)																
BV□□-FRP4-05-3	1/4 Female BSPP	6000 (414)	3000 (207)								0.48 (12.2)	1.24 (31.5)	0.59 (25.0)	2.64 (67.0)	0.77 (19.6)	0.25 (6.4)			
BV□□-FNS4-05-3	1/4 Female NPT	6000 (414)	3000 (207)																
BV□□-RT4-05-3	1/4 Male BSPT	6000 (414)	3000 (207)																
Bv□□-BP4-05-3	1/4 Male BSPP	6000 (414)	3000 (207)																
BV□□-NS4-05-3	1/4 Male NPT	6000 (414)	3000 (207)																
BV□□-RT6-05-3	3/8 Male BSPT	6000 (414)	3000 (207)																
BV□□-BP6-05-3	3/8 Male BSPP	6000 (414)	3000 (207)																
BV□□-NS6-05-3	3/8 Male NPT	6000 (414)	3000 (207)																
								3.24 (82.2)	1.62 (41.1)	1.76 (44.6)									

B-62 Ball Valves

Ball Valves  
Plug Valves

Basic Ordering Number	Connection Type and Size	Pressure Rating of End Connections @ 100°F (38°C), psig (bar)		Orifice in. (mm)	Cv	Dimensions, in. (mm)								
		316 SS	Brass			A	B	C	D	E	F	G	H	I
BV□□-FL8-10-3	1/2" FITOK	6000 (414)	2100 (145)	0.37 (9.5)	3.48	4.68 (118.8)	2.34 (59.4)	2.68 (68.1)	0.71 (18.0)	1.54 (39.0)	1.42 (36.0)	3.78 (96.0)	0.90 (22.9)	0.38 (9.7)
BV□□-FL12-10-3	3/4" FITOK	5800 (400)	1800 (124)			4.66(118.4)	2.33 (59.2)	2.67 (67.9)						
BV□□-ML12-10-3	12 mm FITOK	6000 (414)	2000 (138)			4.84 (123.0)	2.42 (61.5)	2.76 (70.2)						
BV□□-ML14-10-3	14 mm FITOK	6000 (414)	1900 (131)											
BV□□-ML16-10-3	16 mm FITOK	5800 (400)	1700 (117)			3.90 (99.0)	1.95 (49.5)	2.29 (58.2)						
BV□□-ML18-10-3	18 mm FITOK	5400 (372)	1600 (110)											
BV□□-ML20-10-3	20 mm FITOK	5500 (379)	1600 (110)			4.30 (109.2)	2.15 (54.6)	2.49 (63.3)						
BV□□-ML22-10-3	22 mm FITOK	4900 (338)	1450 (100)											
BV□□-FRT6-10-3	3/8 Female BSPT	6000 (414)	3000 (207)			3.97 (101.0)	1.99 (50.5)	2.33 (59.1)						
BV□□-FRP6-10-3	3/8 Female BSPP	6000 (414)	3000 (207)											
BV□□-FNS6-10-3	3/8 Female NPT	6000 (414)	3000 (207)			4.30 (109.2)	2.15 (54.6)	2.49 (63.3)						
BV□□-FRT8-10-3	1/2 Female BSPT	6000 (414)	3000 (207)											
BV□□-FRP8-10-3	1/2 Female BSPP	6000 (414)	3000 (207)			4.50 (114.2)	2.25 (57.1)	2.59 (65.8)						
BV□□-FNS8-10-3	1/2 Female NPT	6000 (414)	3000 (207)											
BV□□-FRT12-10-3	3/4 Female BSPT	6000 (414)	3000 (207)			4.44 (112.8)	2.22 (56.4)	2.56 (65.1)						
BV□□-FRP12-10-3	3/4 Female BSPP	6000 (414)	3000 (207)											
BV□□-FNS12-10-3	3/4 Female NPT	6000 (414)	3000 (207)											
BV□□-RT8-10-3	1/2 Male BSPT	6000 (414)	3000 (207)											
BV□□-BP8-10-3	1/2 Male BSPP	6000 (414)	3000 (207)											
BV□□-NS8-10-3	1/2 Male NPT	6000 (414)	3000 (207)											
BV□□-RT12-10-3	3/4 Male BSPT	6000 (414)	3000 (207)											
BV□□-BP12-10-3	3/4 Male BSPP	6000 (414)	3000 (207)											
BV□□-NS12-10-3	3/4 Male NPT	6000 (414)	3000 (207)											

Angle Pattern Valves

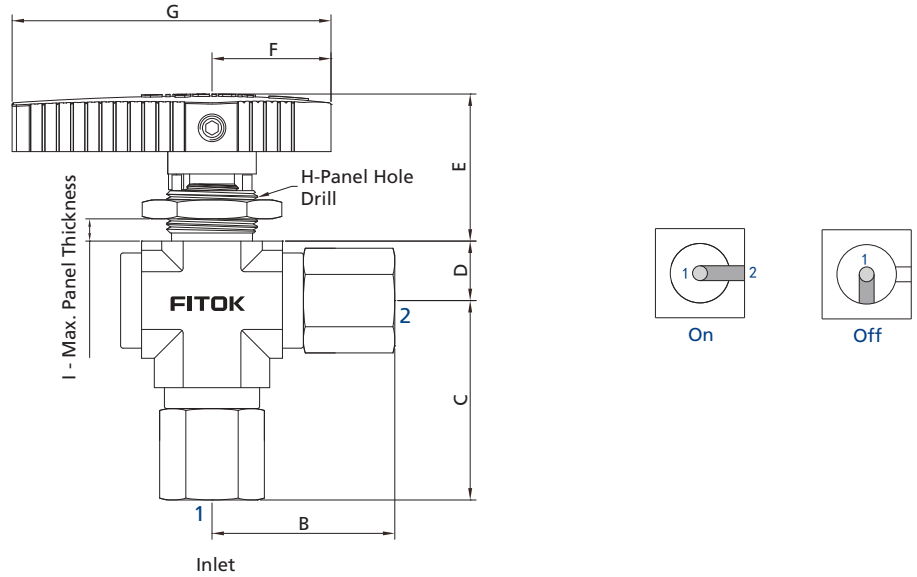

Ball Valves  
Plug Valves

Basic Ordering Number	Connection Type and Size	Pressure Rating of End Connections @ 100°F (38°C), psig (bar)		Orifice in. (mm)	Cv	Dimensions, in. (mm)												
		316 SS	Brass			B	C	D	E	F	G	H	I					
BV□□-FL1-01-A	1/16" FITOK	6000 (414)	3000 (207)	0.05 (1.3)	0.06	1.30 (33.0)	1.35 (34.3)											
BV□□-FL2-02-A	1/8" FITOK	6000 (414)	3000 (207)	0.09 (2.4)	0.21	1.36 (34.5)	1.41 (35.8)											
BV□□-ML3-02-A	3 mm FITOK	6000 (414)	3000 (207)			1.37 (34.8)	1.42 (36.1)											
BV□□-FRT2-04-A	1/8 Female BSPT	6000 (414)	3000 (207)	0.12 (3.0)	0.28	1.07 (27.2)	1.12 (28.5)											
BV□□-FRP2-04-A	1/8 Female BSPP	6000 (414)	3000 (207)															
BV□□-FNS2-04-A	1/8 Female NPT	6000 (414)	3000 (207)							0.33 (8.5)	0.94 (23.9)	0.79 (20.0)	1.97 (50.0)	0.58 (14.7)	0.18 (4.6)			
BV□□-RT2-04-A	1/8 Male BSPT	6000 (414)	3000 (207)					1.18 (30.0)	1.23 (31.3)									
BV□□-BP2-04-A	1/8 Male BSPP	6000 (414)	3000 (207)															
BV□□-NS2-04-A	1/8 Male NPT	6000 (414)	3000 (207)															
BV□□-RT4-04-A	1/4 Male BSPT	6000 (414)	3000 (207)															
BV□□-BP4-04-A	1/4 Male BSPP	6000 (414)	3000 (207)					1.35 (34.3)	1.40 (35.6)									
BV□□-NS4-04-A	1/4 Male NPT	6000 (414)	3000 (207)															
BV□□-FL4-05-A	1/4" FITOK	6000 (414)	3000 (207)			0.19 (4.7)	0.70	1.74 (44.2)	1.88 (47.7)									
BV□□-ML6-05-A	6 mm FITOK	6000 (414)	3000 (207)					1.75 (44.5)	1.89 (48.0)									
BV□□-FL6-05-A	3/8" FITOK	6000 (414)	2200 (152)					1.80 (45.7)	1.94 (49.2)									
BV□□-ML8-05-A	8 mm FITOK	6000 (414)	2300 (159)					1.78 (45.2)	1.92 (48.7)									
BV□□-ML10-05-A	10 mm FITOK	6000 (414)	1900 (131)					1.81 (46.0)	1.95 (49.5)									
BV□□-FRT4-05-A	1/4 Female BSPT	6000 (414)	3000 (207)															
BV□□-FRP4-05-A	1/4 Female BSPP	6000 (414)	3000 (207)					1.51 (38.4)	1.65 (41.9)	0.48 (12.2)	1.24 (31.5)	0.59 (25.0)	2.64 (67.0)	0.77 (19.6)	0.25 (6.4)			
BV□□-FNS4-05-A	1/4 Female NPT	6000 (414)	3000 (207)															
BV□□-RT4-05-A	1/4 Male BSPT	6000 (414)	3000 (207)															
BV□□-BP4-05-A	1/4 Male BSPP	6000 (414)	3000 (207)															
BV□□-NS4-05-A	1/4 Male NPT	6000 (414)	3000 (207)															
BV□□-RT6-05-A	3/8 Male BSPT	6000 (414)	3000 (207)			1.62 (41.1)	1.76 (44.6)											
BV□□-BP6-05-A	3/8 Male BSPP	6000 (414)	3000 (207)															
BV□□-NS6-05-A	3/8 Male NPT	6000 (414)	3000 (207)															

B-64 Ball Valves

Ball Valves  
Plug Valves

Basic Ordering Number	Connection Type and Size	Pressure Rating of End Connections @ 100°F (38°C), psig (bar)		Orifice in. (mm)	Cv	Dimensions, in. (mm)							
	Connection 1/2	316 SS	Brass			B	C	D	E	F	G	H	I
BV□□-FL8-10-A	1/2" FITOK	6000 (414)	2100 (145)	0.37 (9.5)	3.48	2.34(59.4)	2.68(68.1)	0.71 (18.0)	1.54 (39.0)	1.42 (36.0)	3.78 (96.0)	0.90 (22.9)	0.38 (9.7)
BV□□-FL12-10-A	3/4" FITOK	5800 (400)	1800 (124)										
BV□□-ML12-10-A	12 mm FITOK	6000 (414)	2000 (138)										
BV□□-ML14-10-A	14 mm FITOK	6000 (414)	1900 (131)			2.33 (59.2)	2.67 (67.9)						
BV□□-ML16-10-A	16 mm FITOK	5800 (400)	1700 (117)										
BV□□-ML18-10-A	18 mm FITOK	5400 (372)	1600 (110)										
BV□□-ML20-10-A	20 mm FITOK	5500 (379)	1600 (110)			2.42 (61.5)	2.76 (70.2)						
BV□□-ML22-10-A	22 mm FITOK	4900 (338)	1450 (100)										
BV□□-FRT6-10-A	3/8 Female BSPT	6000 (414)	3000 (207)			1.95 (49.5)	2.29 (58.2)						
BV□□-FRP6-10-A	3/8 Female BSPP	6000 (414)	3000 (207)										
BV□□-FNS6-10-A	3/8 Female NPT	6000 (414)	3000 (207)										
BV□□-FRT8-10-A	1/2 Female BSPT	6000 (414)	3000 (207)			2.15 (54.6)	2.49 (63.3)						
BV□□-FRP8-10-A	1/2 Female BSPP	6000 (414)	3000 (207)			1.99 (50.5)	2.33 (59.1)						
BV□□-FNS8-10-A	1/2 Female NPT	6000 (414)	3000 (207)			2.15 (54.6)	2.49 (63.3)						
BV□□-FRT12-10-A	3/4 Female BSPT	6000 (414)	3000 (207)										
BV□□-FRP12-10-A	3/4 Female BSPP	6000 (414)	3000 (207)			2.25 (57.1)	2.59 (65.8)						
BV□□-FNS12-10-A	3/4 Female NPT	6000 (414)	3000 (207)										
BV□□-RT8-10-A	1/2 Male BSPT	6000 (414)	3000 (207)										
BV□□-BP8-10-A	1/2 Male BSPP	6000 (414)	3000 (207)										
BV□□-NS8-10-A	1/2 Male NPT	6000 (414)	3000 (207)										
BV□□-RT12-10-A	3/4 Male BSPT	6000 (414)	3000 (207)			2.22 (56.4)	2.56 (65.1)						
BV□□-BP12-10-A	3/4 Male BSPP	6000 (414)	3000 (207)										
BV□□-NS12-10-A	3/4 Male NPT	6000 (414)	3000 (207)										

1. FITOK means FITOK double ferrule tube fittings.
2. Sizes and types listed are standard. Other sizes and types are available upon request, please contact FITOK Group or our authorized distributors.
3. Dimensions are shown with tube fitting nuts finger-tightened. All dimensions are for reference only and are subject to change.  
For dimensions not shown above, please contact FITOK Group or our authorized distributors.

## Locking Device

- ⦿ Locking Device 1 can lock BV series 2-way or 3-way valves and has a locking hole diameter of 0.21 in (5.2 mm).
- ⦿ To order a ball valve with Locking Device 1, add - L to the valve ordering number.  
Example: BVSS-ML12-10-L/BVSS-ML12-10-3-L
- ⦿ Locking Device 2 can lock BV series 2-way or 3-way valves without affecting panel mounting.
- ⦿ To order a ball valve with Locking Device 2, add - LP to the valve ordering number.  
Example: BVSS-ML12-10-LP/BVSS-ML12-10-3-LP  
A kit for Locking Device 2 is available for adding a locking structure to existing ball valves.



Locking Device 1



Locking Device 2

### Kits for Locking Device 2

Name	Valve Orifice	Locking Hole Diameter	Kit Ordering Number	Content
Locking Device Kits	05, 06	0.21 in (5.2 mm)	BV54-06-LP-RK	Upper lock plate, lower lock plate
	10	0.34 in (8.7 mm)	BV54-10-LP-RK	

## Ball Valve without Handle

- ⦿ Ball Valve without handle can be directly connected to the FITOK actuator assembly.
- ⦿ To order, please add **-AM** to the valve ordering number.  
Example: BVSS-FL4-05-AM

# Ordering Number Description

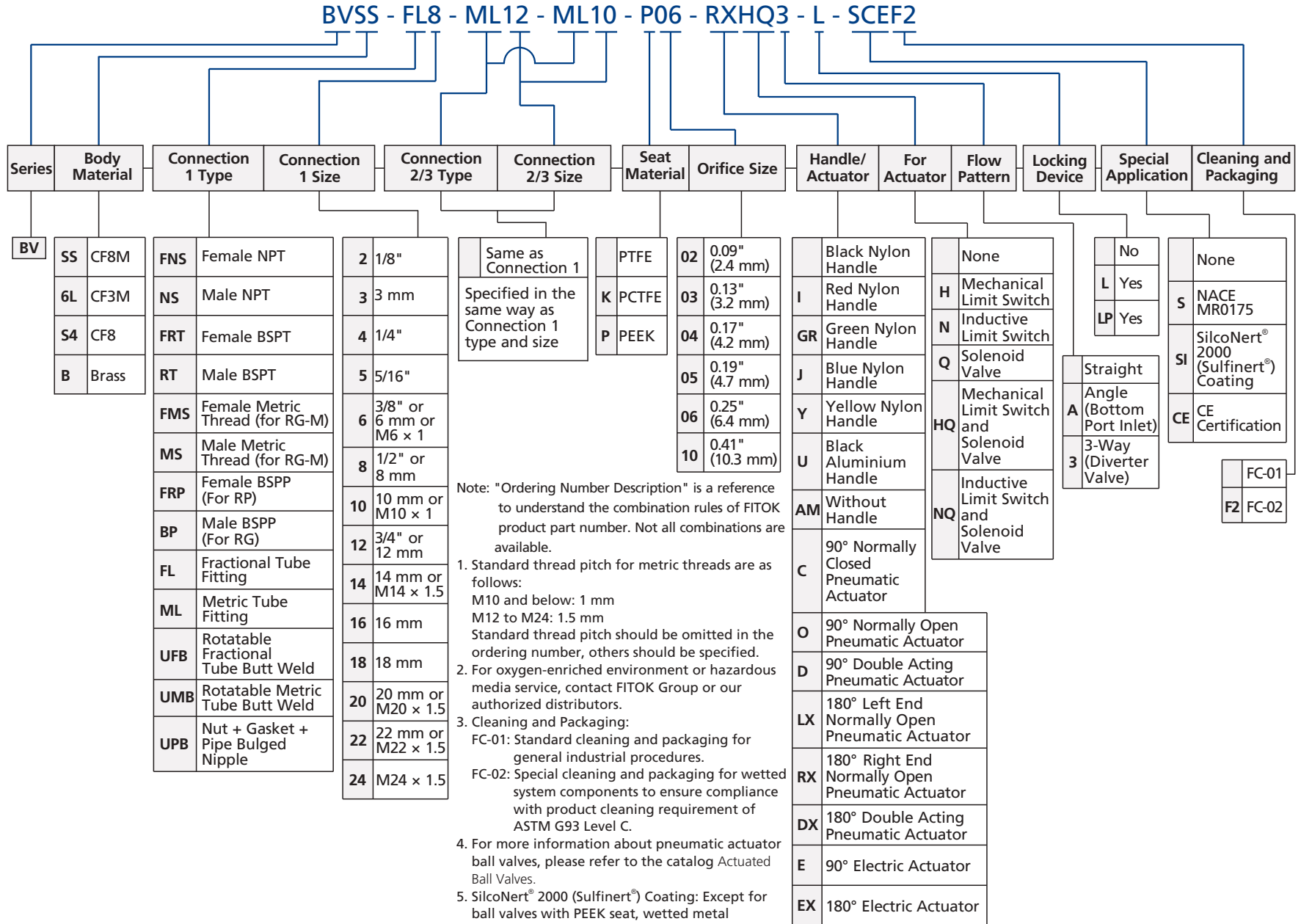

# High Temperature Metal-Seated Ball Valves

## BK Series

### Features

- ⦿ Applied for high temperature and high viscosity liquid medium, not recommended for use in high temperature gas or low viscosity liquid medium
- ⦿ 3-piece precision cast body construction
- ⦿ Free floating ball design provides seat wear compensation
- ⦿ Ball and seats mate-lapped for 100% contact ensures absolute shutoff
- ⦿ High temperature resistant sealing materials for thermal service up to 662°F (350°C)
- ⦿ Blowout-proof stem
- ⦿ Positive handle stop
- ⦿ Orifice sizes: 0.5" (12.7 mm), 1" (25.4 mm), 1.5" (38.1 mm)
- ⦿ Variety of end connections
- ⦿ Test Standard: Low pressure gas tightness FCI 70-2 Class VI  
High pressure liquid test ISO 5208 Rate D

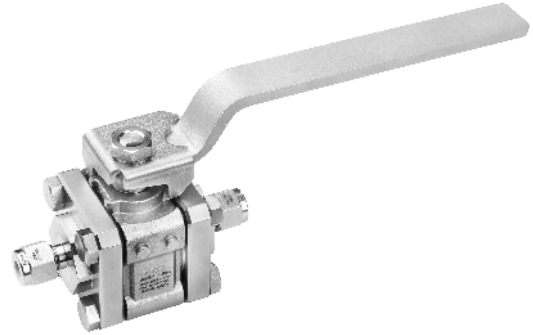

### Technical Data

<b>Orifice, in. (mm)</b>	0.5 (12.7), 1 (25.4), 1.5 (38.1)	
<b>Material</b>	316/304 SS	
<b>Connection Type</b>	FITOK Tube Fitting	Weld Fitting
<b>Temperature, °F (°C)</b>	-65 (-54) to 662 (350)	
<b>Working Pressure, psig (bar)</b>	1000 (69)	

## Standard Materials of Construction

Ball Valves  
Plug Valves

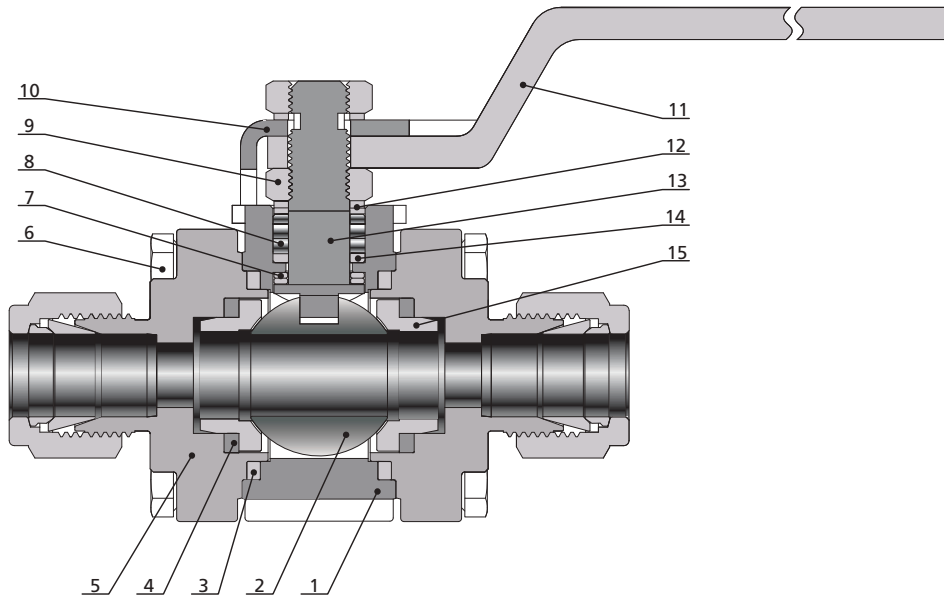

Item	Component	Material	
1	<i>Body</i>	<i>CF8M/A351</i>	<i>CF8/A351</i>
2	<i>Ball</i>	<i>316/304 SS, HVOF-sprayed WC coatings</i>	
3	<i>Flange Seal</i>	<i>Graphite</i>	
4	<i>Seat Packing</i>	<i>Graphite</i>	
5	<i>End Connection</i>	<i>CF8M/A351</i>	<i>CF8/A351</i>
6	Hex Bolt	Stainless Steel	
7	<i>Stem Bearing</i>	<i>Stellite 6/AMS5387</i>	
8	<i>Packing</i>	<i>Graphite</i>	
9	Hex Nut	316 SS/A479	
10	Stop Plate	304 SS/A240	
11	Handle	304 SS/A240	
12	Stem Spring	Strain-hardened 316 SS/A240	
13	<i>Stem</i>	<i>316 SS/A479</i>	
14	<i>Stem Washer</i>	<i>316 SS /A479</i>	
15	<i>Seat</i>	<i>316 SS/A479, hardfacing stellite</i>	<i>304 SS/A479, hardfacing stellite</i>

Note: Wetted components are listed in italics. For other materials, please contact FITOK Group or our authorized distributors.

## Dimensions

Dimensions are for reference only and are subject to change.

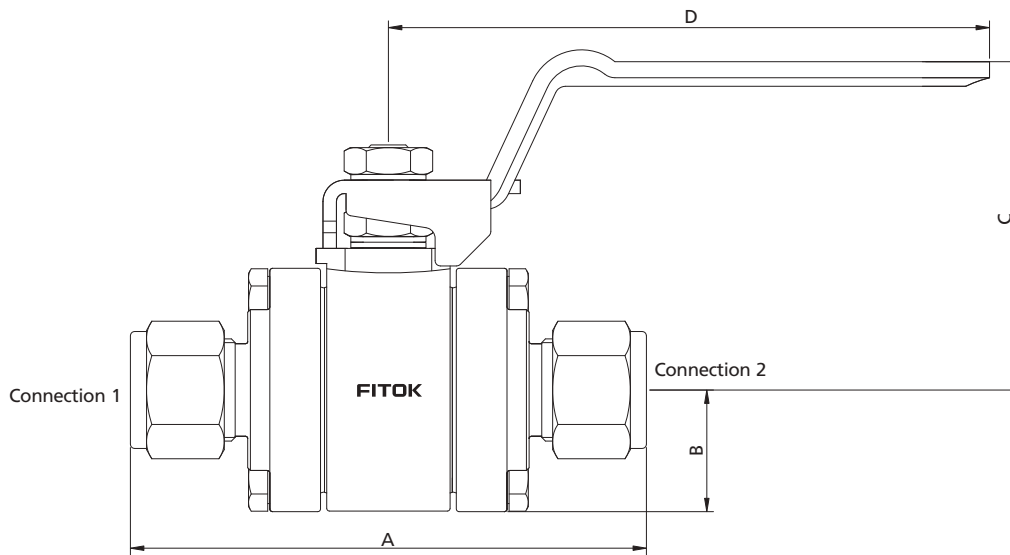

Basic Ordering Information	Connection Type		Orifice in. (mm)	Dimensions, in. (mm)			
	Connection 1	Connection 2		A	B	C	D
BK□□-FL8-13G	1/2" FITOK	1/2" FITOK	0.41 (10.4)	3.79 (96.2)	0.89 (22.7)	2.25 (57.1)	6.5 (165)
BK□□-FL10-13G	5/8" FITOK	5/8" FITOK	0.5 (12.7)	3.79 (96.2)	0.89 (22.7)	2.25 (57.1)	6.5 (165)
BK□□-FL12-13G	3/4" FITOK	3/4" FITOK		3.92 (99.6)	0.89 (22.7)	2.25 (57.1)	6.5 (165)
BK□□-ML16-13G	16 mm FITOK	16 mm FITOK		3.92 (99.6)	0.89 (22.7)	2.25 (57.1)	6.5 (165)
BK□□-ML18-13G	18 mm FITOK	18 mm FITOK		3.91 (99.4)	0.89 (22.7)	2.25 (57.1)	6.5 (165)
BK□□-TB12-13G	3/4" x 0.120" Tube Butt Weld	3/4" x 0.120" Tube Butt Weld		3.8 (96.6)	0.89 (22.7)	2.25 (57.1)	6.5 (165)
BK□□-TS12-13G	3/4" Tube Socket Weld	3/4" Tube Socket Weld		3.2 (80.2)	0.89 (22.7)	2.25 (57.1)	6.5 (165)
BK□□-PB8-13G	1/2 x SCH80 Pipe Butt Weld	1/2 x SCH80 Pipe Butt Weld		3.24 (82.34)	0.89 (22.7)	2.25 (57.1)	6.5 (165)
BK□□-PB12-13G	3/4 x SCH80 Pipe Butt Weld	3/4 x SCH80 Pipe Butt Weld		3.24 (82.34)	0.89 (22.7)	2.25 (57.1)	6.5 (165)
BK□□-TB24-25G	1 1/2" x 0.197" Tube Butt Weld	1 1/2" x 0.197" Tube Butt Weld	1 (25.4)	—	—	—	—
BK□□-TS20-25G	1 1/4" Tube Socket Weld	1 1/4" Tube Socket Weld		—	—	—	—
BK□□-PB20-25G	1 1/4 x SCH80 Pipe Butt Weld	1 1/4 x SCH80 Pipe Butt Weld		—	—	—	—
BK□□-TB32-38G	2" x 0.217" Tube Butt Weld	2" x 0.217" Tube Butt Weld	1.5 (38.1)	—	—	—	—
BK□□-PB24-38G	1 1/2 x SCH80 Pipe Butt Weld	1 1/2 x SCH80 Pipe Butt Weld		—	—	—	—
BK□□-PS24-38G	1 1/2" Pipe Socket Weld	1 1/2" Pipe Socket Weld		—	—	—	—

1. Connection type of "FITOK" means FITOK double ferrule tube fittings.
2. Sizes and types listed are standard. Other sizes and types are available upon request. For details, please contact FITOK Group or our authorized distributors.
3. Dimensions are shown with FITOK tube fitting nuts finger-tight. For dimensions not shown above, please contact FITOK Group or our authorized distributors.

## Ordering Number Description

**BKSS - FL10 - PB8 - 13G**

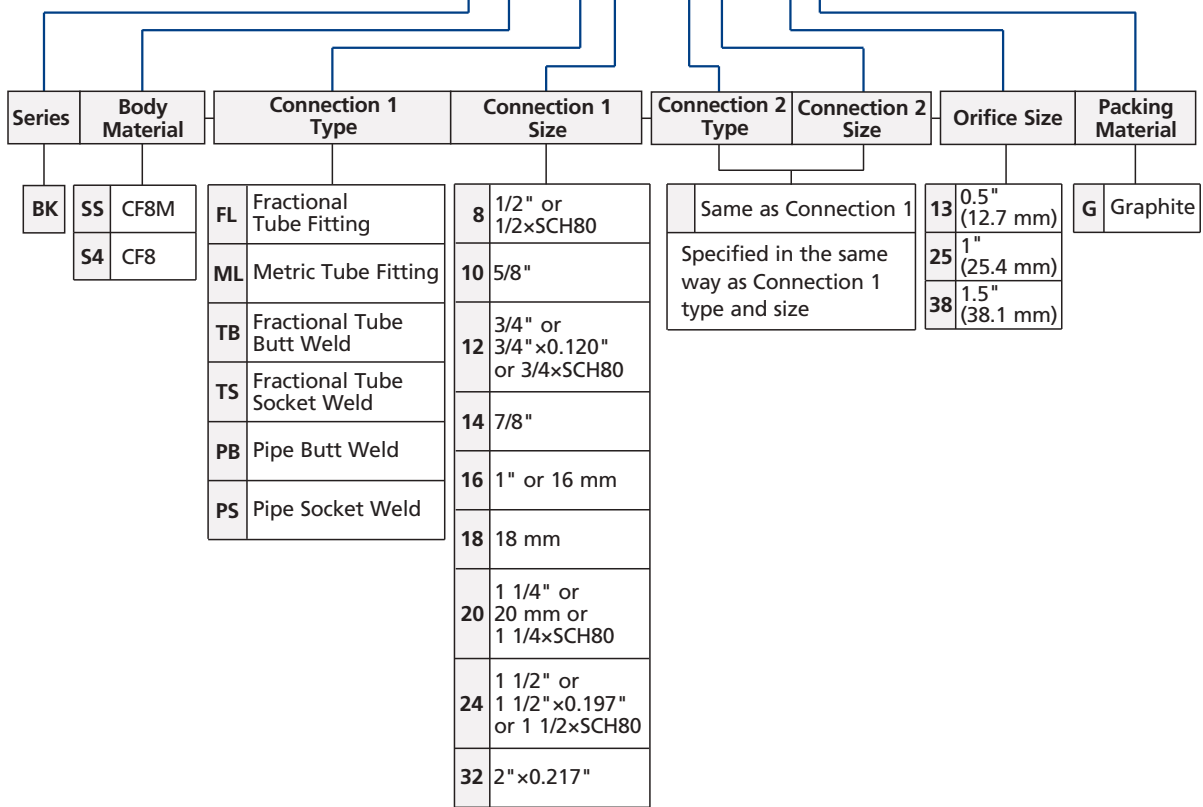

Ball Valves  
Plug Valves

1. If you need a port with orbital welding, please contact FITOK Group.

Note: "Ordering Number Description" is a reference to understand the combination rules of FITOK product part number. Not all combinations are available.

# Alternative Fuel Service (AFS) Ball Valves

## BU Series

### Features

- ⦿ Working pressures up to 6000 psig (414 bar)
- ⦿ Working temperature: -40 to 250°F (-40 to 121°C)
- ⦿ High flow-Cv from 4.0 to 13.8
- ⦿ Low-temperature fluorocarbon material provides sealing capability over full temperature range
- ⦿ Spring-loaded seat provides leak-tight integrity in both low-and high-pressure systems and reduces seat wear from pressure surges
- ⦿ A variety of end connections available
- ⦿ Low operating torque
- ⦿ All wetted components are compatible with hydrogen and compressed natural gas (CNG)
- ⦿ No packing adjustment required
- ⦿ Bidirectional flow
- ⦿ Options for handle colors
- ⦿ Pneumatic actuators available
- ⦿ Each valve is leak tested with nitrogen or compressed air at working pressure to meet a requirement of no visible leak
- ⦿ Field repairable with seal kit
- ⦿ ECE R110 type approval available

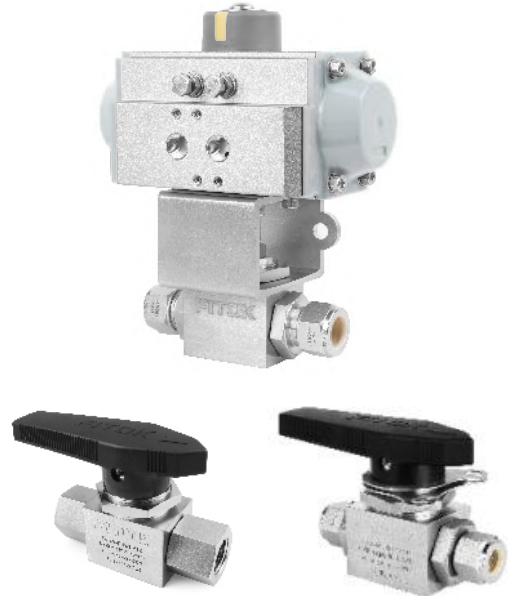

### Pressure VS Temperature Ratings

End Connection	FITOK Tube Fitting			Female Pipe	
	3/8, 1/2 in., 12 mm	3/4 in., 16 mm	1 in.	3/8, 1/2 in.	3/4 in.
Temperature °F (°C)	Working Pressure, psig (bar)				
-40 (-40) ~ 250 (121)	6000 (414)	5800 (400)	4700 (324)	6000 (414)	6000 (414)

Note: Ratings are based on valves of standard materials.

## Standard Materials of Construction

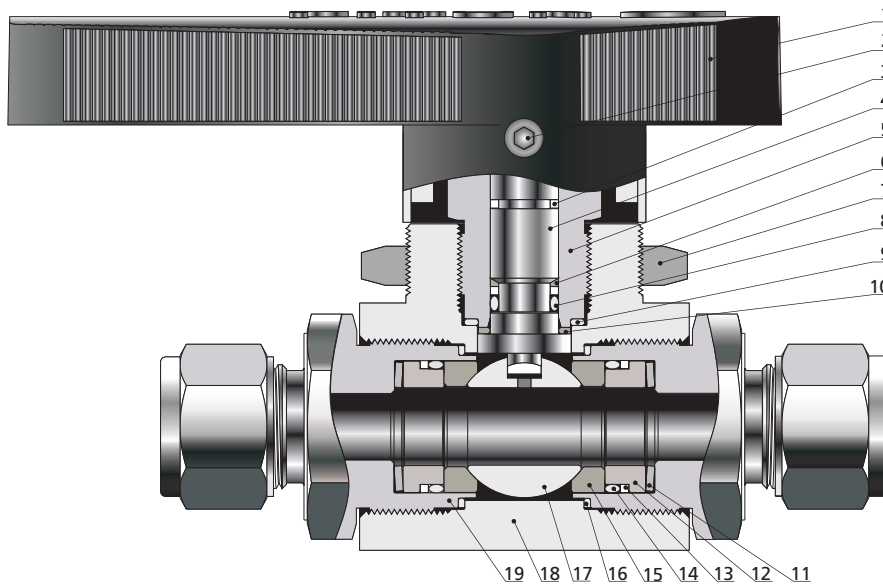

Ball Valves  
Plug Valves

Item	Component	Material/ASTM Specification
1	Handle	Nylon with stainless steel insert
2	Set screw	Zinc-plated carbon steel
3	<i>Guide ring</i>	<i>PTFE/D1710</i>
4	<i>Stem</i>	<i>316 SS/A479</i>
5	<i>Packing bolt</i>	<i>316 SS/A479</i>
6	<i>Stem backup ring</i>	<i>PEEK</i>
7	Lock nut	316 SS/A479
8	<i>Stem O-ring</i>	<i>Low-temperature fluorocarbon</i>
9	<i>Packing bolt washer</i>	<i>Silver-plated 316 SS/A269</i>
10	<i>Thrust washer</i>	<i>PEEK</i>
11	<i>Coned-disc spring</i>	<i>316 SS/A240</i>
12	<i>Seat gland</i>	<i>316 SS/A479</i>
13	<i>Seat backup ring</i>	<i>PTFE/D1710</i>
14	<i>Seat O-ring</i>	<i>Low-temperature fluorocarbon</i>
15	<i>Seat</i>	<i>PEEK</i>
16	<i>End connection gasket</i>	<i>Silver-plated 316 SS/A269</i>
17	<i>Ball</i>	<i>316 SS/A479</i>
18	<i>Body</i>	<i>316 SS/A479</i>
19	<i>End connection</i>	<i>316 SS/A479</i>
	<i>Lubricant</i>	<i>PTFE-based</i>

Note: Wetted components listed in italics.

## Dimensions

Dimensions in in. (mm) are for reference only and subject to change.

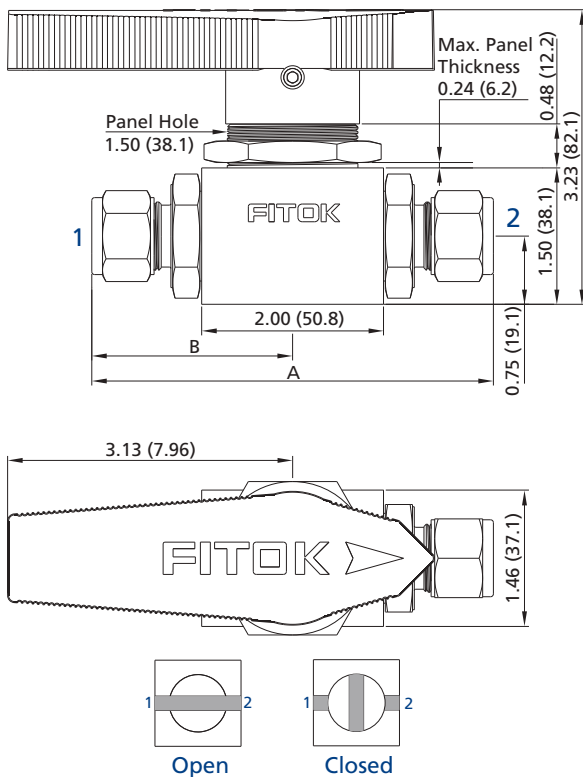

Ordering Number	Connection <sup>①</sup> Type and Size	Cv	Orifice in. (mm)	Dimensions in. (mm)	
				A	B
BUSS-ML10-P12	10 mm FITOK	5.2	0.31 (7.9)	4.21 (107)	2.11 (53.5)
BUSS-ML12-P12	12 mm FITOK	5.2	0.41 (10.3)	4.42 (112.2)	2.21 (56.1)
BUSS-ML16-P12	16 mm FITOK	12.4	0.47 (12.0)	4.42 (112.3)	2.21 (56.2)
BUSS-FL6-P12	3/8" FITOK	4.0	0.28 (7.1)	4.20 (106.6)	2.10 (53.3)
BUSS-FL8-P12	1/2" FITOK	7.2	0.41 (10.3)	4.40 (111.8)	2.20 (55.9)
BUSS-FL12-P12	3/4" FITOK	7.1	0.47 (12.0)	4.50 (114.3)	2.46 (62.5)
BUSS-FL16-P12	1" FITOK	6.5	0.47 (12.0)	4.93 (125.1)	2.25 (57.1)
BUSS-FNS6-P12	3/8" Female NPT	11.0	0.47 (12.0)	4.01 (102)	2.00 (50.8)
BUSS-FNS8-P12	1/2" Female NPT	13.8		4.01 (102)	2.00 (50.8)
BUSS-FNS12-P12	3/4" Female NPT	7.8		4.13 (105)	2.06 (52.3)
BUSS-FRT8-P12	1/2" Female BSPT	13.8		4.01 (102)	2.00 (50.8)

Note: Dimensions shown with FITOK tube fitting nuts finger-tight. Valves can be ordered with two different end connections. Contact FITOK Group or our authorized distributors. Not recommended for panel mounting; not available with pneumatic actuator.

## CNG/NGV Application

ECE R110 Manual Service Valve Type Approval

Classification: Class 0

Temperature: -40 to 248°F (-40 to 120°C)

Pressure: 3370 psig (260 bar)

To order, add **-R110** to the valve ordering number.

Example: BUSS-ML12-P12-**R110**

Seal kit for field replacement is available, see "Seal Kits".

## Seal Kits

Seal Kit Name	Seal Kit Ordering Number	Seal Kit Content
Seat seal kit	SS-BU-P-SE	Seat, seat backup ring, seat O-ring, coned-disc spring, end connection gasket, instructions.
Stem and seat seal kit	SS-BU-P	Guide ring, stem backup ring, stem O-ring, packing bolt washer, thrust washer, seat, seat backup ring, seat O-ring, coned-disc spring, end connection gasket, instructions

## Locking Device

- ⦿ Locking Device 1 can lock BU series valves and has a locking hole diameter of 0.21 in (5.2 mm).
- ⦿ To order a ball valve with Locking Device 1, add - **L** to the valve ordering number.  
Example: BUSS-ML12-P12- **L**
- ⦿ Locking Device 2 can lock BU series valves without affecting panel mounting and has a locking hole diameter of 0.34 in (8.7 mm).
- ⦿ To order a ball valve with Locking Device 2, add - **LP** to the valve ordering number.  
Example: BUSS-ML12-P12- **LP**
- ⦿ A kit for Locking Device 2 is available for adding a locking structure to existing ball valves.



Locking Device 1



Locking Device 2

### Kits for Locking Device 2

Name	Kit Ordering Number	Content
Locking Device Kits	BUS4-12-LP-RK	Upper lock plate, lower lock plate, handle, hexagon socket set screws

## Ball Valve without Handle

- ⦿ Ball Valve without handle can be directly connected to the FITOK actuator assembly.
- ⦿ To order, please add -**AM** to the valve ordering number.  
Example: BUSS-FL8-P12-**AM**

# Ordering Number Description

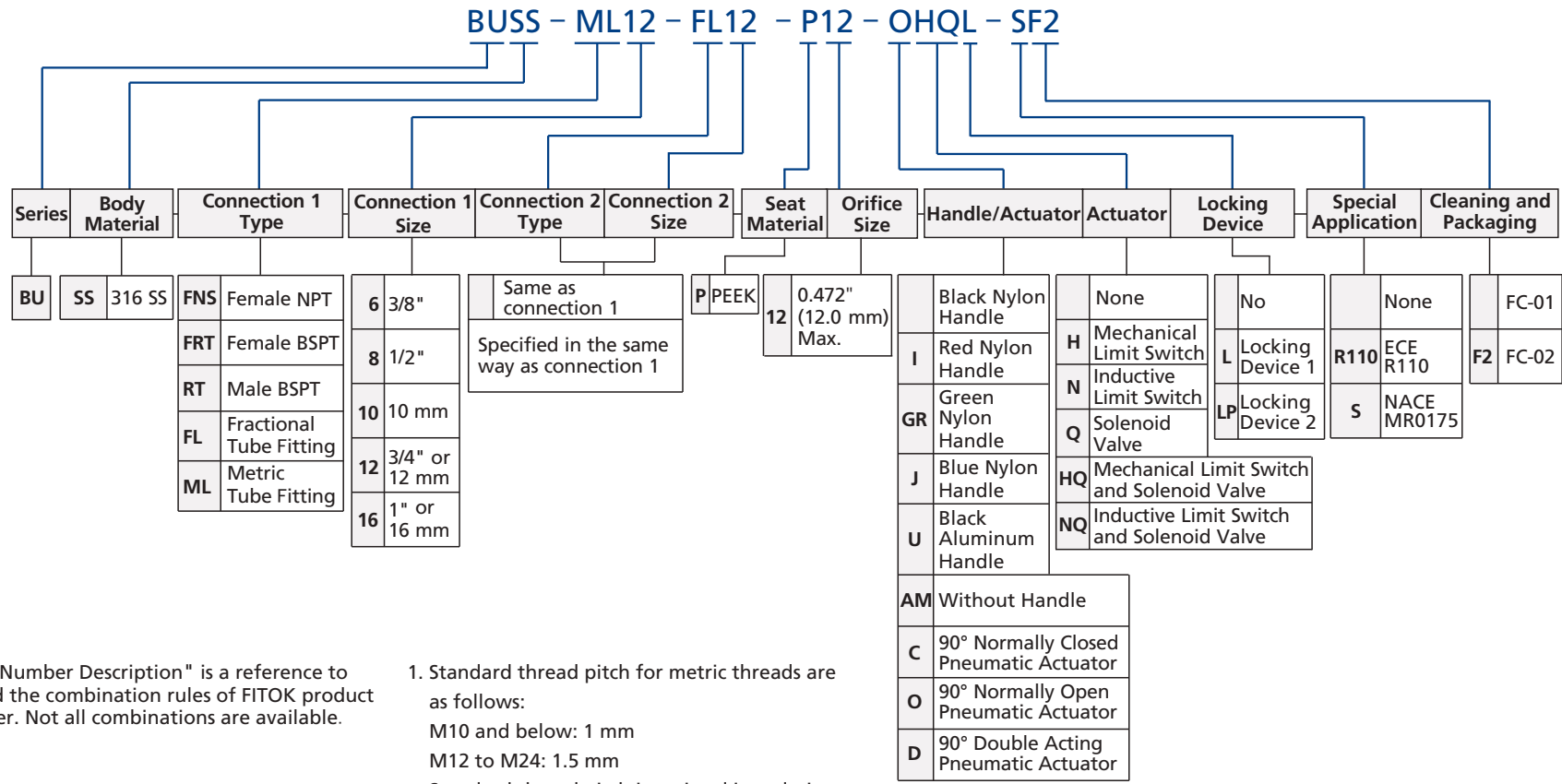

Note: "Ordering Number Description" is a reference to understand the combination rules of FITOK product part number. Not all combinations are available.

- Standard thread pitch for metric threads are as follows:  
 M10 and below: 1 mm  
 M12 to M24: 1.5 mm  
 Standard thread pitch is omitted in ordering number.  
 For special thread pitch, specify in the ordering number.
- For oxygen-enriched environment or hazardous media service, contact FITOK Group or our authorized distributors.
- Cleaning and Packaging:  
 FC-01: Standard cleaning and packaging for general industrial procedures.  
 FC-02: Special cleaning and packaging for wetted system components to ensure compliance with product cleaning requirement of ASTM G93 Level C.
- For more details about ball valves with pneumatic actuators, refer to Actuated Ball Valves.
- Certifications do not include attachments to the valve, such as actuators or a different handle mechanism.